

# Internet 3.0: The Next Generation Internet

**Raj Jain**  
**Professor of CSE**

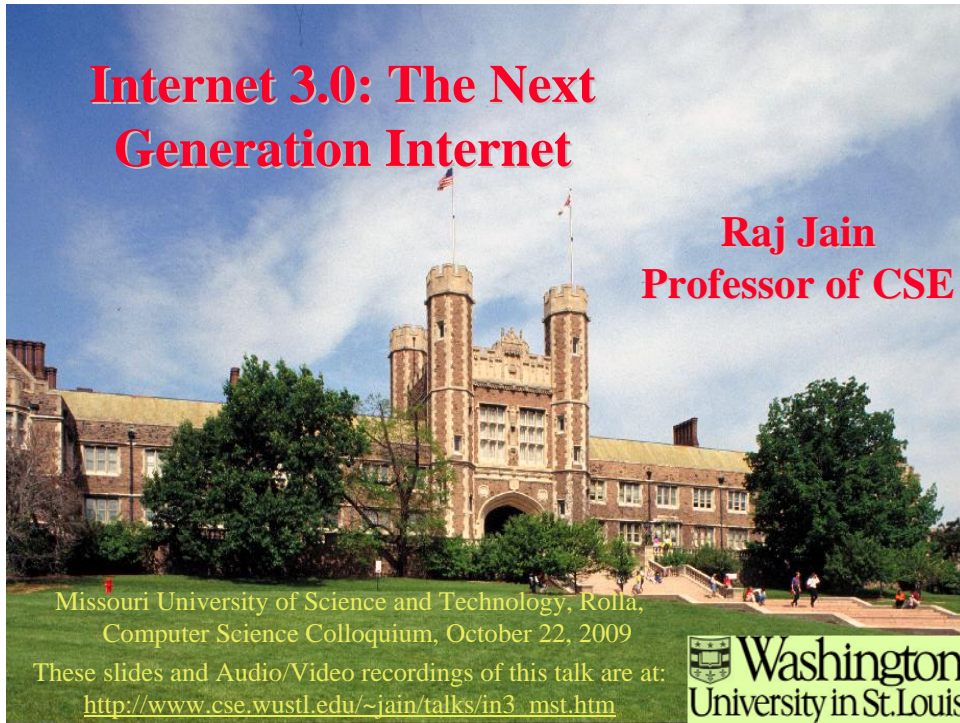

## Graduate Study @ Washington University

- ❑ 24 faculty members, 71 Ph.D. students, in:
  - Robotics, Graphics, HCI, AI/Bioinformatics, networking, high-performance architectures, chip multi-processors, mobile systems/sensor networks, software systems, optimization.
- ❑ PhD students are (almost always) fully funded.
- ❑ Special emphasis on individual mentorship and on interdisciplinary opportunities
- ❑ Recent graduates on faculty at U. Mass, UT-Austin, Rochester, RIT, CMU, Michigan St., UNC-Charlotte.
- ❑ Application deadline Jan 15, <http://www.cs.wustl.edu>
- ❑ Information Day on Saturday, November 14 (10am-3pm)



1. What is Internet 3.0?
2. What are we missing in the current Internet?
3. Our Proposed Architecture for Internet 3.0

## Next Generation Internet Projects

- ❑ In 2005 US National Science Foundation started a large research and infrastructure program on next generation Internet
- ❑ Q: How would you design Internet today? Clean slate design.
- ❑ “Future Internet Design” (FIND): 48+ projects
  - ❑ Stanford, MIT, Berkeley, CMU, ...
  - ❑ “An Architecture for Diversified Internet” at WUSTL
- ❑ “Global Environment for Networking Innovations” (GENI): 29+ projects
- ❑ European Union: 7<sup>th</sup> Framework program
- ❑ Japan: AKARI (A small light in the dark pointing to the future)
- ❑ China, Korea, Australia, ...20+ countries
- ❑ **Ref:** See our survey report, WUSTL-2009-69, Oct 2, 2009

## Internet 3.0: Next Generation Internet

- ❑ Internet 3.0 is the name of the Washington University project on the next generation Internet
- ❑ Goal 1: Represent the commercial reality of distributed Internet ownership and organization
- ❑ Goal 2: Develop a *clean slate architecture* to overcome limitations of the current internet
- ❑ Goal 3: Develop an *incremental approach* to implement the architecture



## Internet Generations

- ❑ **Internet 1.0** (1969 – 1989) – Research project
  - RFC1 is dated April 1969.
  - ARPA project started a few years earlier
  - IP, TCP, UDP
  - Mostly researchers
  - Industry was busy with proprietary protocols: SNA, DECnet, AppleTalk, XNS
- ❑ **Internet 2.0** (1989 – Present) – Commerce ⇒ new requirements
  - Security RFC1108 in 1989
  - NSFnet became commercial
  - Inter-domain routing:  
BGP (Policy-based)
  - Address Shortage IPv6
  - Congestion Control, Quality of Service,...

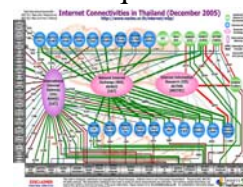
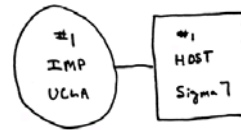

## Key Problems with Current Internet

### 1. Security:

Fundamental architecture design issue  
Control+Data are intermixed  
Security is just one of the policies.



### 2. No concept of **ownership**

(except at infrastructure level)  
Difficult to represent organizational, administrative hierarchies and relationships. Perimeter based.

⇒ Difficult to enforce organizational policies

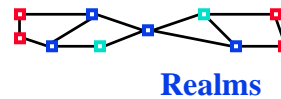
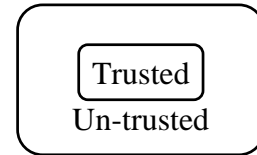

## Problems (cont)

3. Identity and location in one (IP Address)  
Makes mobility complex.



4. Assumes live and awake end-systems  
Does not allow communication while sleeping.  
Many energy conscious systems today sleep.



5. No representation for real end system: the human.



Ref: Our Milcom 2006 paper

## Physical vs. Logical Connectivity

- ❑ Physically and logically connected:  
All computers in my lab  
= Private Network,  
Firewalled Network
- ❑ Physically disconnected but logically connected:  
My home and office computers
- ❑ Physically connected but logically disconnected: Passengers on a plane,  
Neighbors, Conference attendees sharing a wireless network, A visitor



**Physical connectivity  $\neq$  Trust**

## Names, IDs, Locators



**Name:** John Smith

**ID:** 012-34-5678

**Locator:**  
1234 Main Street  
Big City, MO 12345  
USA

- ❑ Locator changes as you move, ID and Names remain the same.
- ❑ **Examples:**
  - Names: Company names, DNS names (microsoft.com)
  - IDs: Cell phone numbers, 800-numbers, Ethernet addresses, Skype ID, VOIP Phone number
  - Locators: Wired phone numbers, IP addresses

## Realms

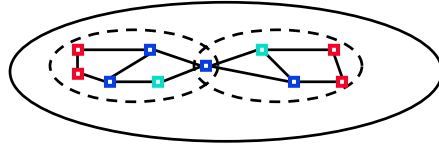

- ❑ Object names and Ids are defined within a realm
- ❑ A realm is a **logical** grouping of objects under an administrative domain
- ❑ The Administrative domain may be based on Trust Relationships
- ❑ A realm represents an organization
  - Realm managers set policies for communications
  - Realm members can share services.
  - Objects are generally members of multiple realms
- ❑ Realm Boundaries: Organizational, Governmental, ISP, P2P,...

**Realm = Administrative Groupvc**

## Id-Locator Split Architecture (MILSA)

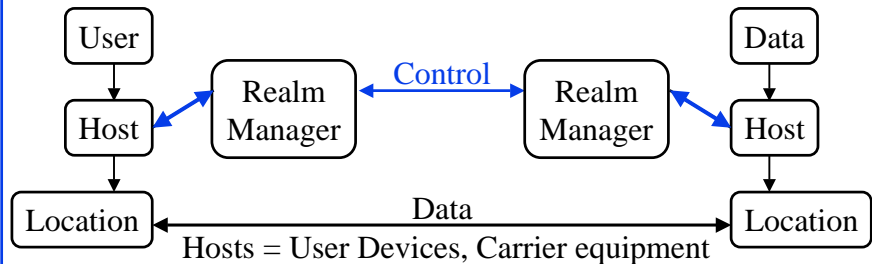

### Realm managers:

- ❑ Resolve current location for a given host-ID
- ❑ Enforce policies related to authentication, authorization, privacy
- ❑ Allow mobility, multi-homing, location privacy
- ❑ Different from several other ID-locator splitting proposals.  
Our Emphasis on organizational control.
- ❑ Ref: Our Globecom 2008 paper [2]

## User- Host- and Data Centric Models

- ❑ All discussion so far assumed host-centric communication
  - Host mobility and multihoming
  - Policies, services, and trust are related to hosts
- ❑ User Centric View:
  - Bob wants to watch a movie
  - Starts it on his media server
  - Continues on his iPhone during commute to work
  - Movie exists on many servers
  - Bob may get it from different servers at different times or multiple servers at the same time
- ❑ Can we just give IDs/locators to users and treat them as hosts?
  - No! ⇒ Policy Oriented Naming Architecture (PONA)



## Policy-Based Networking Architecture

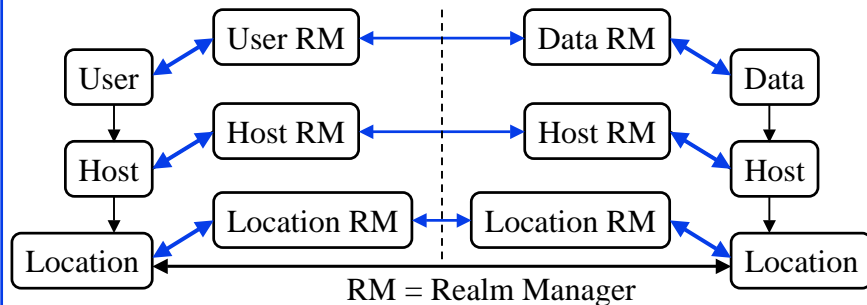

- ❑ Both Users and data need hosts for communication
- ❑ Data is easily replicable/divisible. All copies are equally good.
- ❑ Users, Hosts, Infrastructure, Data belong to different realms (organizations).
- ❑ Each object has to follow its organizational policies.

## Multi-Tier Object-Oriented View

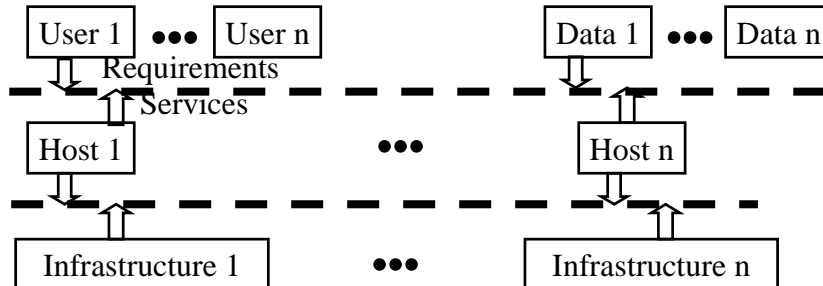

- ❑ Objects provide services. Higher tiers specify the requirements
- ❑ Tier service broker (shown by dotted line) composes a service – can negotiate with multiple realms in that tier
- ❑ Higher tier may not/need not find details of lower tiers

Allows creating requirement specific networking context

## Disruption Tolerant Network (DTN)

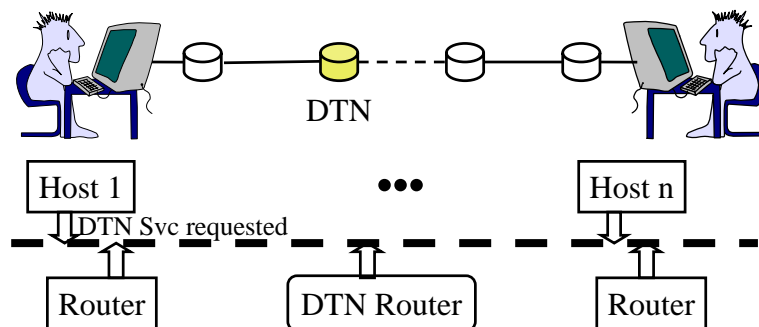

- ❑ Normally all routers on the end-to-end path should be up
- ❑ DTN-aware routers store data until it can be forwarded
- ❑ In Internet 3.0, DTN service can be advertised by DTN routers and negotiated by the service broker

## Multi-Tier Issues

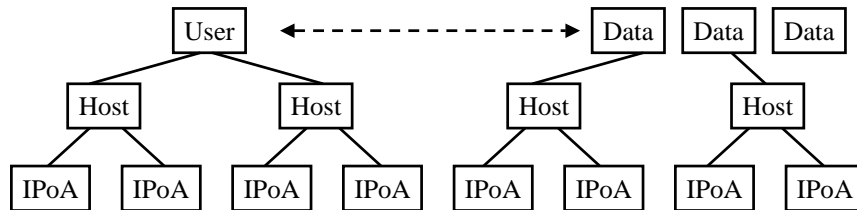

- ❑ **Multi-Tier Multi-homing:** Users are accessible via multiple hosts. Each host has multiple Infrastructure Point of Attachments (IPoAs)
- ❑ **Multi-Tier Mobility:** Users are constantly changing hosts. Hosts are changing their IPoAs.
- ❑ **Multi-Tier Virtualization**

## Cloud Computing

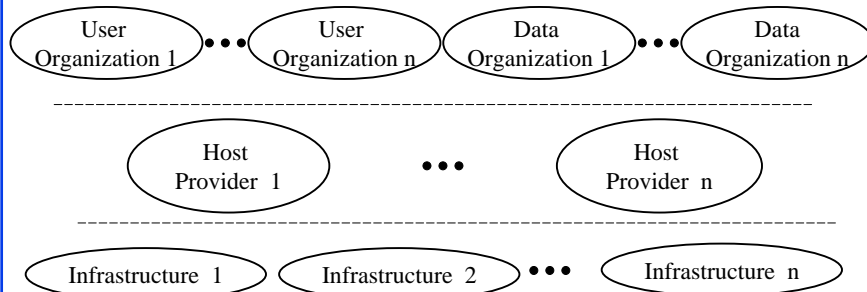

- ❑ **Other Examples:**
  - P2P: File sharing groups over hosts over infrastructure
  - Distributed Services: Services over multi-homed hosts
  - National Security: Infrastructure vs. national boundaries

## Tiers of Cellular Networks

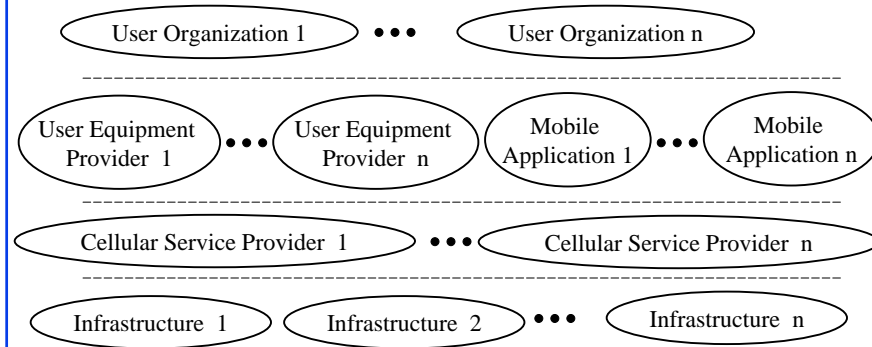

## Internet 1.0 vs. Internet 3.0: Features

	<b>Feature</b>	<b>Internet 1.0</b>	<b>Internet 3.0</b>
1.	Energy Efficiency	Always-on	Energy aware
2.	Mobility	Mostly stationary computers	Mostly mobile <i>objects</i>
3.	Computer-Human Relationship	Multi-user systems ⇒ Machine to machine comm	Multi-systems user ⇒ Personal comm systems
4.	End Systems	Single computers	User/Data/Distributed systems
5.	Design Goal	Research ⇒ Trusted Systems <b>Govt Funded</b>	Commerce ⇒ No Trust Map to organizational structure
6.	Ownership	No concept of ownership	Hierarchy of ownerships

<b>Internet 1.0 vs. Internet 3.0: Design</b>			
	<b>Design Issue</b>	<b>Internet 1.0 Solution</b>	<b>Internet 3.0 Solution</b>
1	Resource allocation	Algorithmic Optimization	Policy based
2	Intelligence	Manual/applications	In the network
3	Connections	Host-Host	User-Data (Hosts are intermediate systems)
4.	Ownership	Single=> Single Tier	Commercial Reality => Multi-Tier
5	Information	Complete knowledge of all tiers	Only service API's are disclosed
6	Mobility	Host mobility	Multi-tier mobility (User/data/host)
7	Multi-homing	Host multihoming	Multi-tier multihoming (User/Data/Host)
8	Virtualization	Network virtualization	Multi-Tier virtualization



[http://www.cse.wustl.edu/~jain/talks/in3\\_mst.htm](http://www.cse.wustl.edu/~jain/talks/in3_mst.htm)
©2009 Raj Jain

21

## Summary



1. Internet 3.0 is the next generation of Internet.
2. It must be secure, allow mobility, and be energy efficient.
3. Must be designed for commerce  
 ⇒ Must represent multi-organizational structure and policies
4. Different ownership/policies of users, hosts, infrastructure  
 ⇒ Multi-tier, object oriented, service broker architecture
5. Object-oriented architecture allows services to be composed that meet upper tier's requirements while not requiring disclosure of lower tier's mechanisms and details

[http://www.cse.wustl.edu/~jain/talks/in3\\_mst.htm](http://www.cse.wustl.edu/~jain/talks/in3_mst.htm)
©2009 Raj Jain

22

## References

1. Jain, R., “**Internet 3.0: Ten Problems with Current Internet Architecture and Solutions for the Next Generation**,” in Proceedings of Military Communications Conference (MILCOM 2006), Washington, DC, October 23-25, 2006, <http://www.cse.wustl.edu/~jain/papers/gina.htm>
2. Subharthi Paul, Raj Jain, Jianli Pan, and Mic Bowman, “**A Vision of the Next Generation Internet: A Policy Oriented View**,” British Computer Society Conference on Visions of Computer Science, Sep 2008, <http://www.cse.wustl.edu/~jain/papers/pona.htm>
3. Jianli Pan, Subharthi Paul, Raj Jain, and Mic Bowman, “**MILSA: A Mobility and Multihoming Supporting Identifier-Locator Split Architecture for Naming in the Next Generation Internet**,” Globecom 2008, Nov 2008, <http://www.cse.wustl.edu/~jain/papers/milsa.htm>

## References (Cont)

4. Jianli Pan, Raj Jain, Subharthi Paul, Mic Bowman, Xiaohu Xu, Shanzhi Chen, “**Enhanced MILSA Architecture for Naming, Addressing, Routing and Security Issues in the Next Generation Internet**,” Proceedings of IEEE International Conference in Communications (ICC) 2009, Dresden, Germany, June 14-18, 2009, (sponsored by Huawei) <http://www.cse.wustl.edu/~jain/papers/emilsa.htm>
5. Jianli Pan, Subharthi Paul, Raj Jain, Xiaohu Xu, “**Hybrid Transition Mechanism for MILSA Architecture for the Next Generation Internet**,” Proceedings of IEEE Globecom 2008 2nd International Workshop on the Networks of the Future, Hawaii, December 4, 2009, <http://www.cse.wustl.edu/~jain/papers/milsat.htm>

## References (Cont)

6. Subharthi Paul, Jianli Pan, and Raj Jain, "Architectures for the Future Networks and the Next Generation Internet: A Survey," WUSTL Technical Report, WUCSE-2009-69, October 2, 2009, 59 pp.,  
<http://www.cse.wustl.edu/~jain/papers/i3survey.htm>



**Thank  
you**

