

Forward Explicit Congestion Notification (FECN) for Datacenter Ethernet Networks

Jinjing Jiang, Raj Jain, Chakchai So-In
Washington University In Saint Louis
Saint Louis, MO 63130
Jain@wustl.edu

IEEE 802.1au Congestion Notification Group Meeting,
Orlando, FL, March 12-15, 2007

These slides are also available on-line at
<http://www.cse.wustl.edu/~jain/ieee/fecn703.htm>



- ❑ Top 10 Requirements for a Good Scheme
- ❑ FECN Overview
- ❑ Switch Algorithm and Enhancements
- ❑ Simulation Results
 - ❑ FECN with TCP flows
 - ❑ Symmetric Topology
 - ❑ Large Topology
 - ❑ Bursty Traffic



Datacenter Networks

- ❑ Bounded delay-bandwidth product
 - ❑ High-speed: 10 Gbps
 - ❑ Short round-trip delays
 - ❑ 1 Mb to 5 Mb delay-bandwidth product
- ❑ Storage Traffic \Rightarrow short access times \Rightarrow Low delay
- ❑ Packet loss \Rightarrow Long timeouts \Rightarrow Not desirable



Goals of FECN

1. Fast convergence to stability in rates
Stable rates \Rightarrow TCP Friendly (IETF feedback)
2. Fast convergence to fairness
3. Good for bursty traffic \Rightarrow Fast convergence
4. Efficient operation: minimize unused capacity. Minimize chances of switch $Q=0$ when sources have traffic to send
5. Extremely low (or zero) loss
6. Predictable performance: No local minima
7. Easy to deploy \Rightarrow Small number of parameters
8. Easy to set parameters
9. Parameters applicable to a wide range of network configurations link speeds, traffic types, number of sources.
10. Applicable to a variety of switch architectures and queueing/scheduling disciplines



FECN Overview

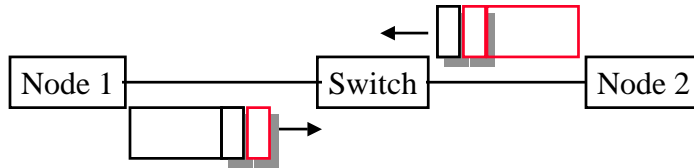

- ❑ Periodically, the sources piggyback a “Rate Discovery Tag” (RD tag) on the outgoing packet.
- ❑ The tag contain only rate, Rate limiting Q ID, and direction. (Direction = Forward (discovery) tag or Returning tag)
- ❑ The sender initializes the RD tag with rate=-1 ($\Rightarrow \infty$)
- ❑ The switches adjust the rate down if necessary
- ❑ The receiver copies the forward RD tag in a control packets in the reverse direction
- ❑ Source adjusts to the rate received



FECN: Observations

- ❑ This is similar to what is done in TCP/IP, Frame Relay, ATM with 1 bit in every packet ($n=1$).
- ❑ ATM ABR had a similar explicit rate indication that was selected after 1 year of intense debate and scrutiny.
- ❑ Only the feedback format has to be standardized
- ❑ No need to standardize switch algorithm.
- ❑ Vendor differentiation: Different switch algorithms will “inter-operate” although some algorithms will be more efficient, more fair, and achieve efficiency/fairness faster than others.
- ❑ We present a sample switch algorithm and show that it achieves excellent performance.



Switch Algorithm

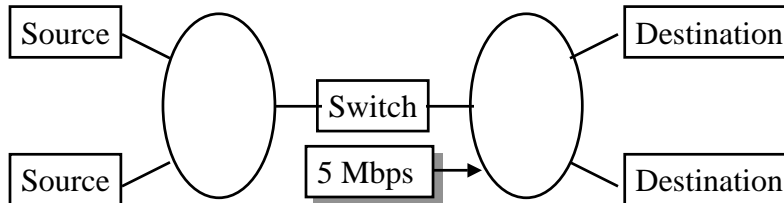

- The switch use the same “**Advertised Rate**” in all RD tags
- All sources passing through the switch get the same feedback.
- The sources send at the rate received.



The Basic Switch Algorithm

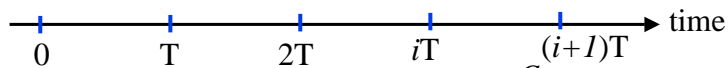

0. Start with an Advertised Rate of r . $r_0 = \frac{C}{N_0}$
Here C is the link capacity.
1. Measure input rate every T interval
2. Compute overload factor z in the last T interval
3. Change the advertised rate to r/z
4. In every RD tag: set rate to $\min\{\text{rate in tag, advertised rate}\}$
5. Go back to step 1

Although this simple algorithm will work but:

- It will oscillate even if the rate is close to optimal.
- Queues will not be constant \Rightarrow **Need a Q Control Fn**



Enhancement 1: Queue-Control

1. **Measurement:** Let A_i be the measured arrival rate in bits/s then the load factor is $z = A_i/C$. We update this load factor based on the queue length so that the *effective load factor* is:

$$\rho_i = \frac{z}{f(q_i)} = \frac{A_i}{f(q_i) \times C}$$

2. **Bandwidth Allocation:**

$$r_{i+1} = \frac{r_i}{\rho_i}$$

Note: We also tried additive queue control. It has similar performance.



Queue Control Function: $f(q)$

Idea: Give less rate if queue length is large and more if queue length is small compared to desired queue length of Q_{eq} and

$$f(Q_{eq})=1$$

$$f(q) = \begin{cases} \geq 1 & q \leq Q_{eq} \\ = 1 & q = Q_{eq} \\ \leq 1 & q \geq Q_{eq} \end{cases} \text{ Reserves some capacity for draining the queue.}$$

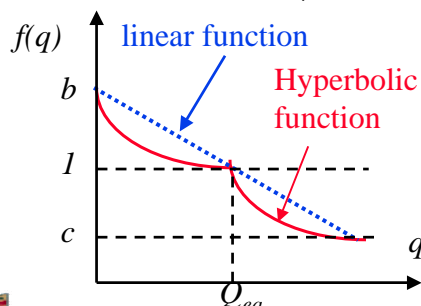

We analyzed many different functions and recommend the hyperbolic function because it gives smaller oscillations. [See reference]



Queue Control Function (Cont)

- **Linear Function:** k is some constant

$$f(q) = 1 - k \frac{q - Q_{eq}}{Q_{eq}}$$

- **Hyperbolic function:** a, b, c are constants. Pre-computed in a table.

$$f(q) = \begin{cases} \frac{bQ_{eq}}{(b-1)q + Q_{eq}}, & \text{if } q \leq Q_{eq}; \\ \max\left(c, \frac{aQ_{eq}}{(a-1)q + Q_{eq}}\right), & \text{otherwise.} \end{cases}$$

| q | f(q) |
|---|------|
| | |
| | |
| | |
| | |
| | |
| | |
| | |
| | |
| | |
| | |

In all simulations, $a = 1.1$, $b = 1.002$, $c = 0.1$



Enhancement 2: Exponential Averaging

Exponentially weighted average in the Switch:

$$r_{i+1} = \alpha \frac{r_i}{\rho_i} + (1 - \alpha)r_{i-1}$$

$$\alpha \in (0,1)$$

Remembers recent history. In all simulations $\alpha = 0.5$



Enhancement 3: Limited Rate Increase

Limit rate increase in the switch

```

IF ( $q < Q_{eq}$ ) THEN
   $\Delta R = 1.414\Delta R$ 
ELSE IF ( $q > Q_{sc}$ ) THEN
   $\Delta R = 0.707\Delta R$ 
END IF
IF ( $r_i - r_{i-1} > \Delta R$ ) THEN
   $r_i = r_{i-1} + \Delta R$ 
END IF
    
```

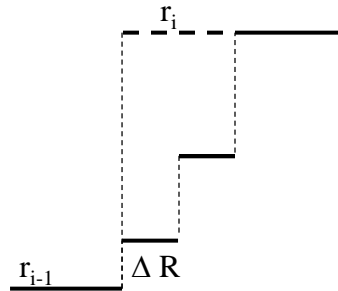

- **Strategy:** Take small jumps. Jump size increases with every step. Results in fast rise time but avoids sudden queue increase if false signal.



Enhancement 4: Variable Capacity Adjustment

- If capacity of the link reduces due to failure of a component link in an aggregated link or other reasons, the allocated rate is reduced accordingly.

```

IF ( $c_i < c_{i-1}$ ) THEN
   $r_i = (c_i/c_{i-1})r_i$ 
   $r_{i-1} = (c_i/c_{i-1})r_{i-1}$ 
END IF
 $r_{i-2} = r_{i-1}$ 
 $r_{i-1} = r_i$ 
    
```

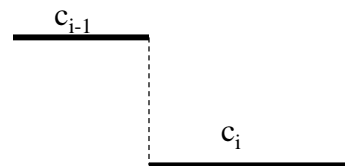

Enhancement 5: Time Based Sampling

Time-based sampling at the source: Packet tagged if time since the last time tag was sent is more than τ

In all simulations $\tau = T$



General Simulation Parameters

- Queue control function: Hyperbolic
- Packet size = 1500 B
- Measurement interval $T = 1$ ms



Baseline Simulation Results

1. FECN with TCP flows
2. Symmetric Topology
3. **Large** Topology with 100 flows
4. **Bursty Traffic**: Pareto-distributed burst time
5. Output-Generated **Hot-Spot** Scenario
6. Output-Generated Hot-Spot Scenario with **long delay**

All simulations use the same parameter values!



FECN with TCP flows

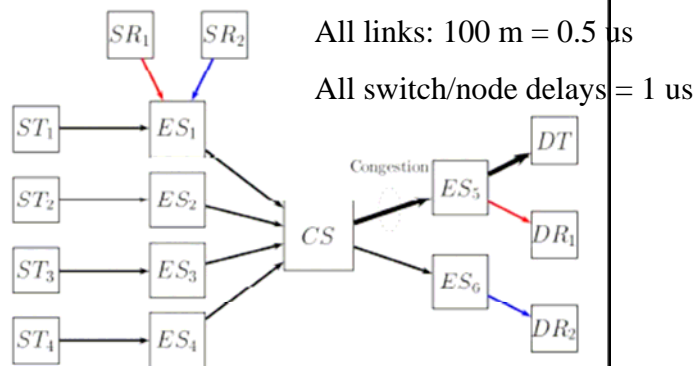

- ❑ 6-source topology
- ❑ SR1-to-DR1 and SR2-to-DR2 are *reference flows*
- ❑ SR₁-to-DT are four flows that share the bottleneck link



FECN with TCP flows (Cont)

- $T = 1$ ms
- Total simulation time = 1 sec
- Workload
 - ST1-ST4: 10 parallel TCP connections transferring 1 MB each continuously
1 Transaction = 1 MB transfer
 - Reference flows: 1 TCP connection transferring 10kB each with average idle time of 16 us for SR1 and 1 us for SR2



Simulation Results

| | Reference Flow 1 | | | Reference Flow 2 | | |
|----------------------|-----------------------------|-------------------|----------------------------------|-----------------------------|-------------------|----------------------------------|
| Congestion Mechanism | Throughput (Transactions/s) | Throughput (Gbps) | Transaction Completion Time (us) | Throughput (Transactions/s) | Throughput (Gbps) | Transaction Completion Time (us) |
| None | 556 | 0.06 | 1780.78 | 16634 | 1.44 | 59.11 |
| FECN | 6970 | 0.604 | 127.63 | 16630 | 1.44 | 59.16 |

| Congestion Mechanism | Average Throughput (Gbps) | Jain Fairness Index | Link Utilization (%) |
|----------------------|---------------------------|---------------------|----------------------|
| None | 2.49 | 2% | 99.9 |
| FECN | 2.35 | 99% | 99.9 |

Conclusions: FECN can protect fragile TCP flows and improve its goodput and fairness significantly. FECN reduced packet loss from 50,008 packets to 0 packets.



Symmetric Topology: Configuration

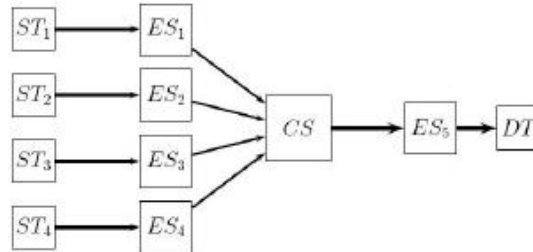

- UDP *Bernoulli Traffic* with average 5 Gbps rate
- Measurement Interval T is 1 ms, $N_0 = 20$
- Simulation Time is 100 ms, all sources starts at 5 ms
- At 80 ms, 2 sources stop
- Per-hop-delay=0.5 us, switch/node delay is 1 us



Symmetric Topology: Source Throughput

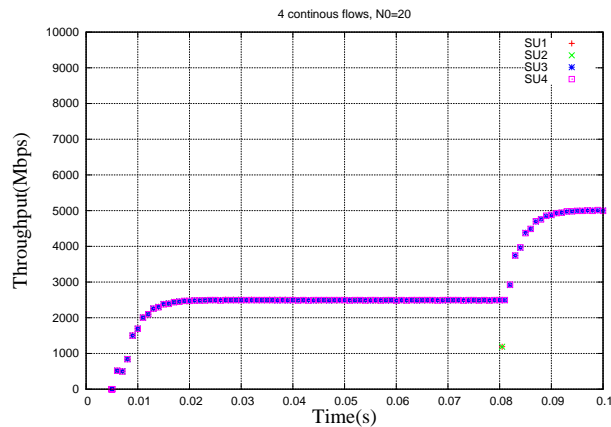

Conclusions:

- Four sources overlap \Rightarrow Perfect Fairness!
- Fast Convergence: around 10 ms



Symmetric Topology: Queue Length

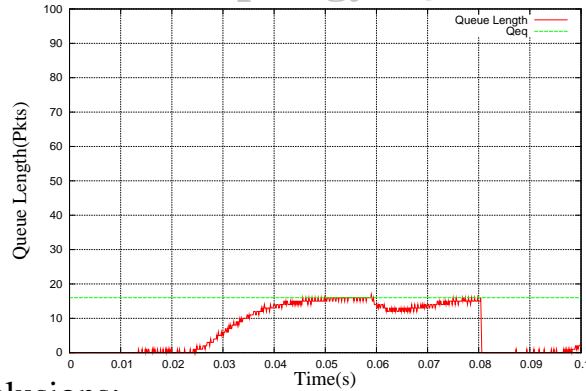

Conclusions:

- Queue builds up to Q_{eq} and can stay there.
- Queue never overflows



Symmetric Topology: Link Utilization

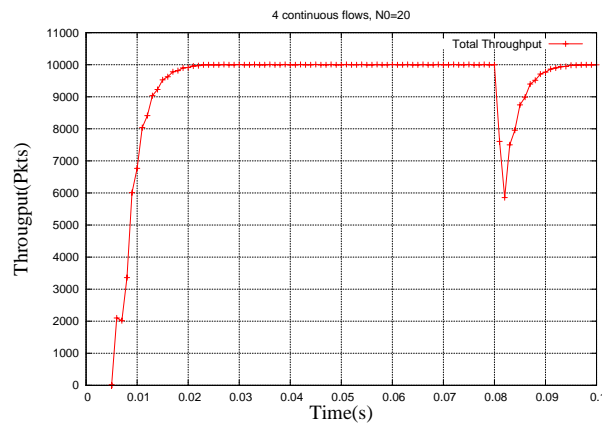

- Link is highly utilized when the rate achieves the fair share in around 10 ms.



Simple Topology, 400us Delay

- Round delay is 400 us
- Each link and station delay is 50 us
- No very clear effect due to long delay in this simple case



Symmetric Topology LD: Source Throughput

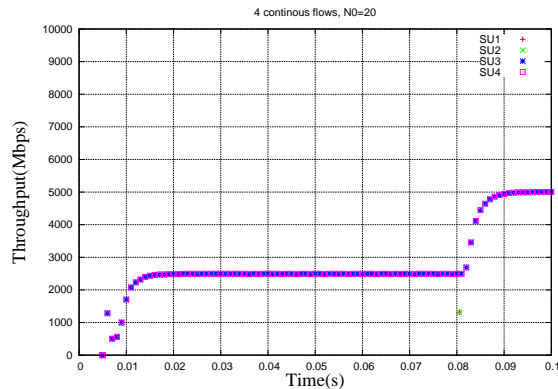

□ Conclusions:

- Four sources overlap \Rightarrow Perfect Fairness!
- Fast Convergence: around 10 ms



Symmetric Topology LD: Queue Length

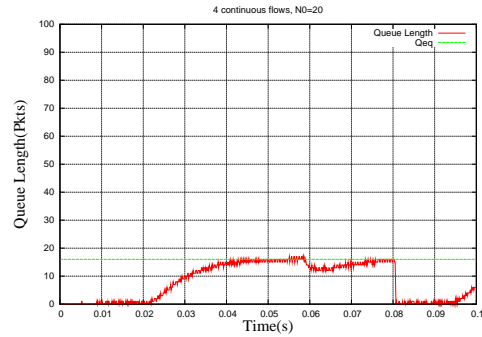

Conclusions:

- Queue builds up to Q_{eq} and can stay there.
- Queue never overflows



Sym. Topology LD: Link Utilization

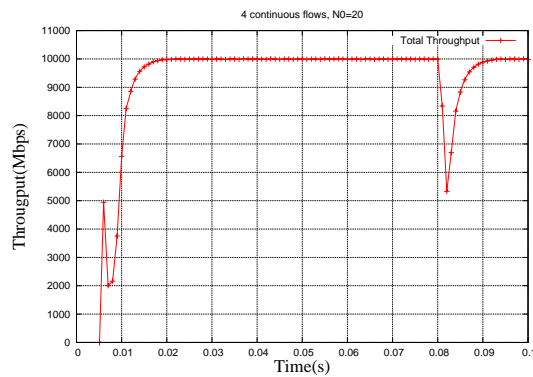

- Link is highly utilized when the rate achieves the fair share in around 10 ms.



Large Topology: Configuration

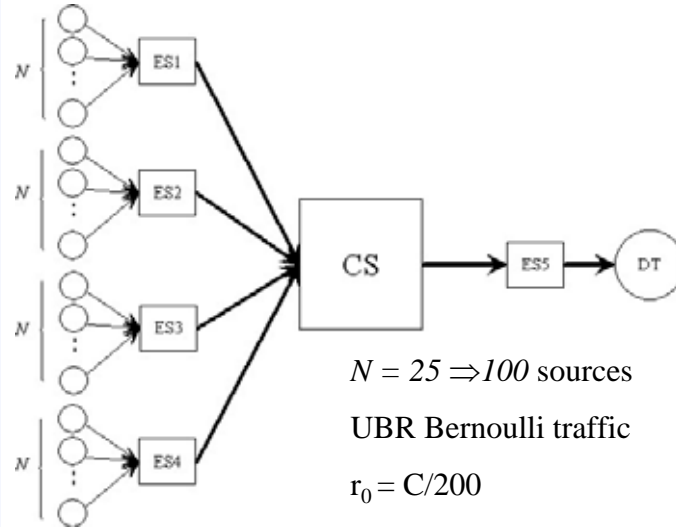

Large Topology: Source Rates

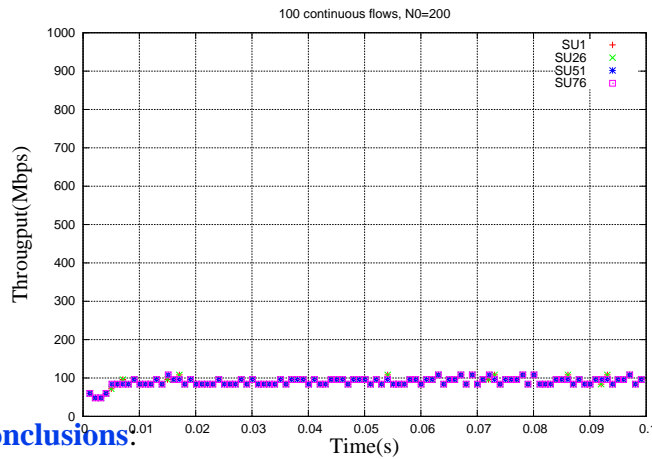

□ Conclusions:

- Perfect Fairness!
- Fast Convergence: less than 10 ms



Large Topology: Link Utilization

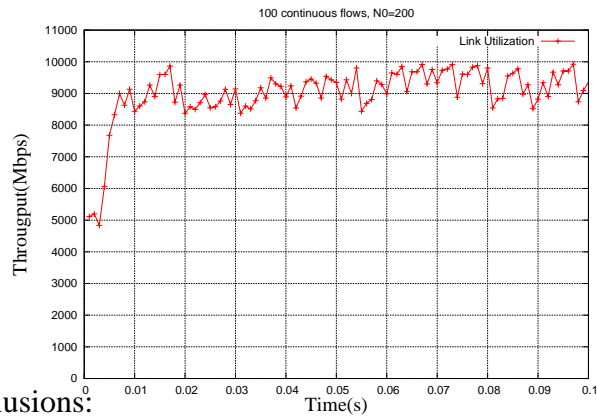

- Conclusions:
 - The link is still 90+% utilized on average



Large Topology: Queue Length

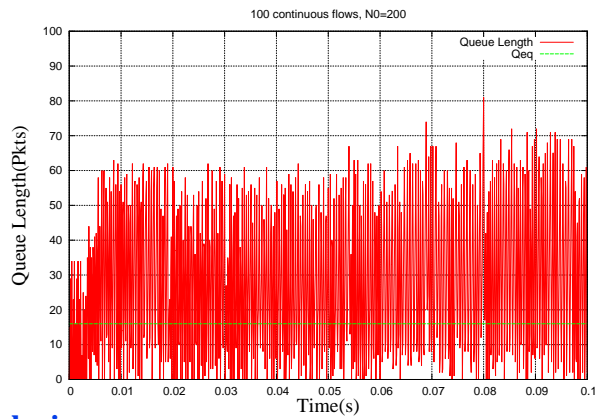

- Conclusions:
 - Queue does not overflow!
 - No PAUSE required or issued



PAUSE

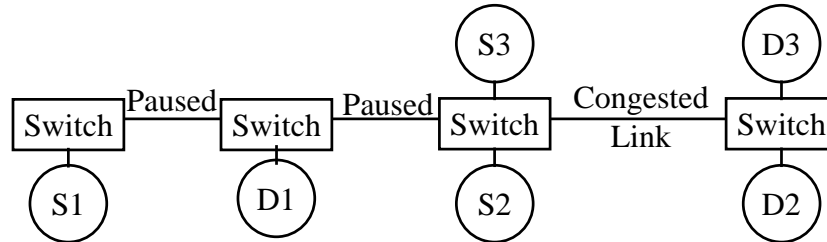

- ❑ S1-to-D1 flow is not using congested resources but is stopped by congestion caused by S2-to-D2 and S3-to-D3
- ❑ **Conclusion:**
 - ❑ Pause unfairly affects non-congestion causing flows
 - ❑ Pause should not be used as a primary or frequent mechanism
 - ❑ Pause can reduce loss but increase delays in the network
 - ❑ Pause is an emergency mechanism for rare use



Bursty Traffic: Configuration

- ❑ Large Topology (100 Sources)
- ❑ The sources come on and go off after transmitting a burst.
- ❑ The ON/OFF period is Pareto distributed
- ❑ Average ON/OFF period is *10* ms

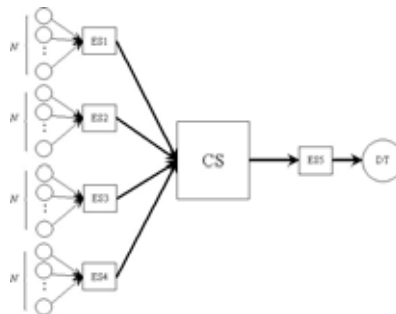

Large Topology - Bursty Traffic: Throughput

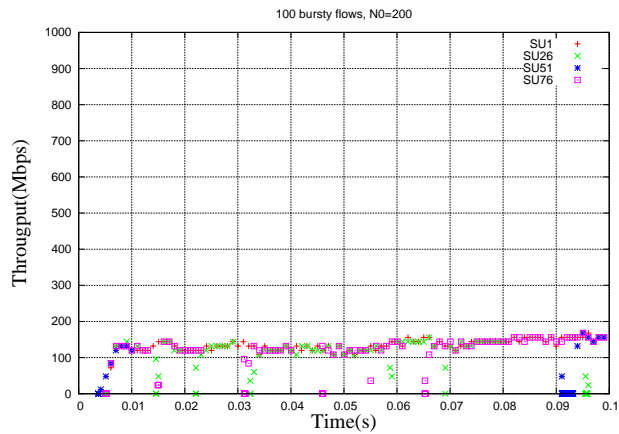

□ **Conclusion:** Perfect Fairness!



Large Topology - Bursty Traffic: Link Utilization

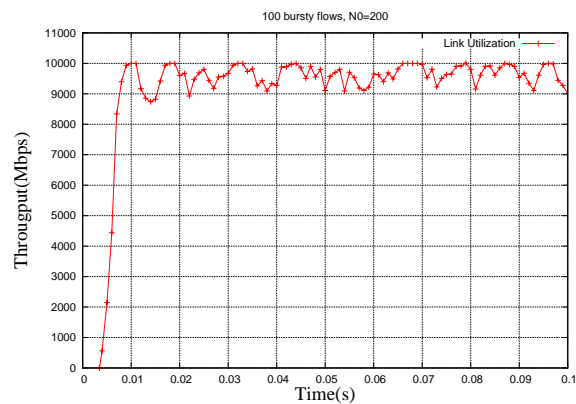

□ **Conclusion:** On average, the link is 95+% utilized



Large Topology - Bursty Traffic: Queue

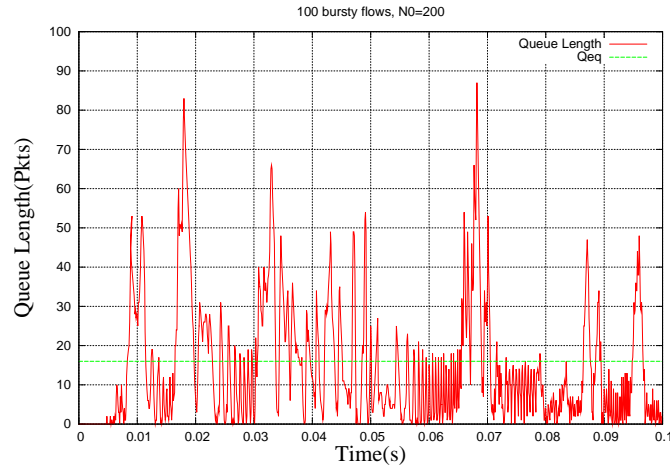

- **Conclusion:** Queue length is always under the buffer size. No pause required for this case.



Output Generated Hotspot Scenario

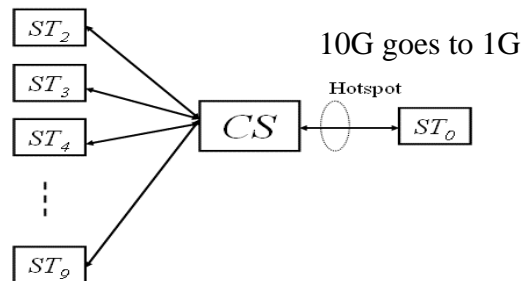

1. Capacity from CS to ST_0 goes to 1 G from 0.01 s to 0.09 s , then come back to 10 Gbps
2. We study per flow behavior instead of per node behavior
3. Symmetric topology configuration is used
4. Capacity $C(t)$ is known from the idle time and bits transmitted.



OGHS – Uncongested Link (ST2 to CS)

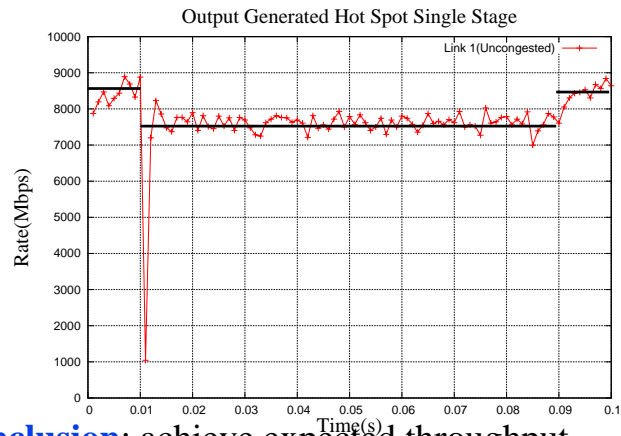

□ **Conclusion:** achieve expected throughput



OGHS – Congested Link (CS to ST0)

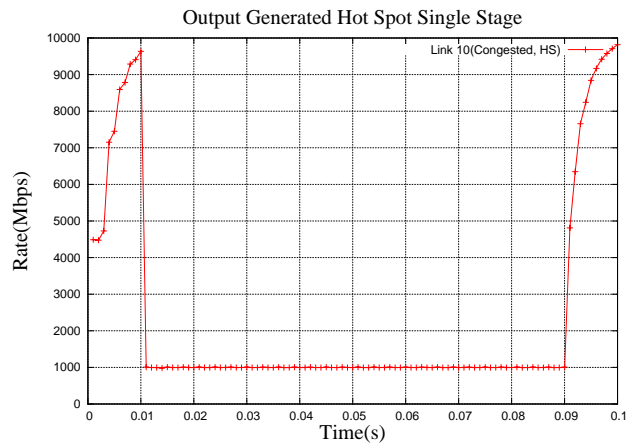

□ **Conclusion:** Fast convergence. Highly utilized link!



OGHS – 9 Congested Flows

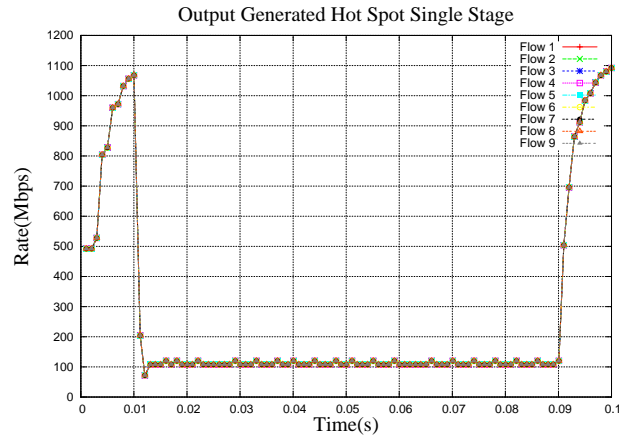

□ **Conclusion:** Perfect fairness among 9 flows!



OGHS - Queue Length

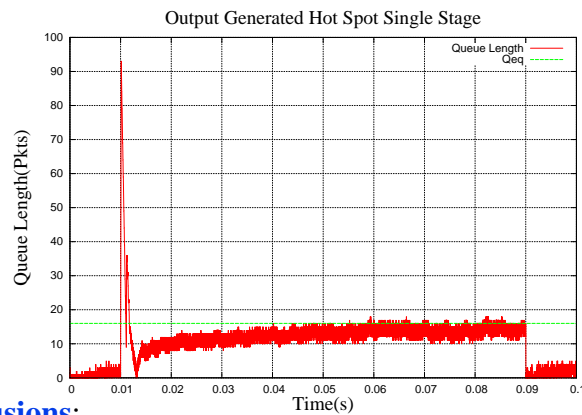

Conclusions:

- One very short Pause event (capacity reduced from 10G to 1G).
- The queue is very stable at the equilibrium point



OGHS – Long Delay

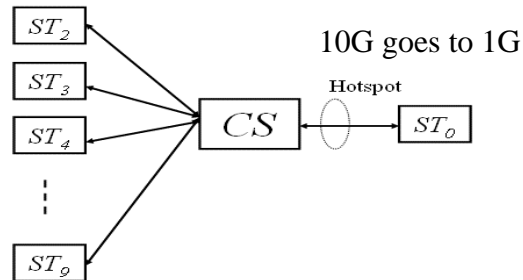

1. Each link 124 us long
2. Total feedback delay = 500 us



OGHS-LD: Uncongested Link - ST2 to CS

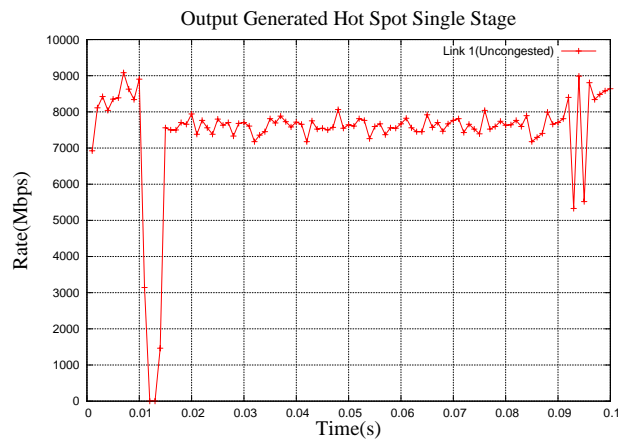

Conclusion: FECN recovers quickly



OGHS-LD: Congested Link (CS to ST0)

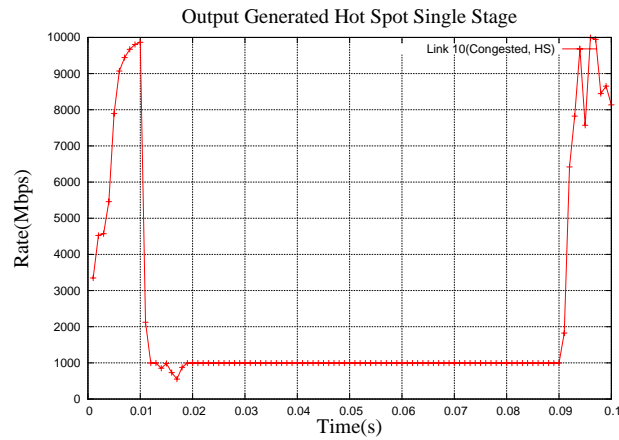

□ **Conclusion:** Link throughput is stable.



OGHS-LD: 9 Congested Flows

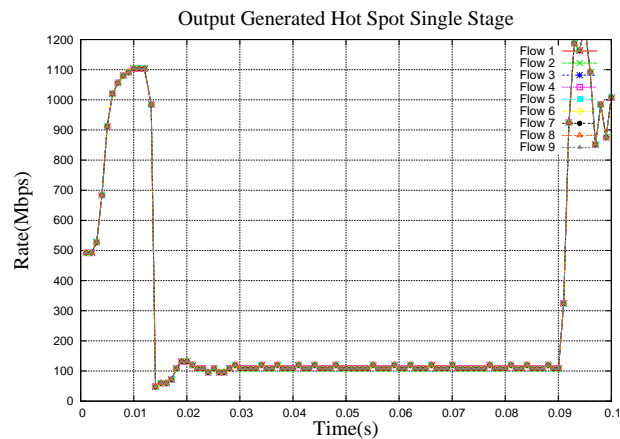

□ **Conclusion:** Perfect fairness



OGHS-LD: Queue Length

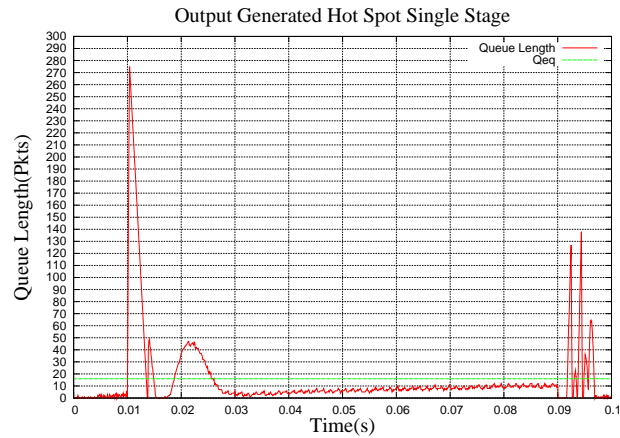

- ❑ **Conclusion:** FECN works for long delay without any change in any parameters



OGHS-LD: Other Observations

- ❑ Pause On/Off Threshold is 90/8 packets...
- ❑ 3 Pause events
- ❑ Total pause duration 0.0045 s



Minimum Buffering Required w Pause

- ❑ Need 1 RTT buffer to allow queue to not go to zero after a Pause OFF
 - ⇒ Pause OFF threshold = 1 RTT+2 packets
 - ⇒ Pause ON Threshold = 2 x Pause OFF = 2 RTT
- ❑ Need 1 RTT extra buffer to not drop any packets after a Pause ON
- ❑ Total Buffer = 3 RTT

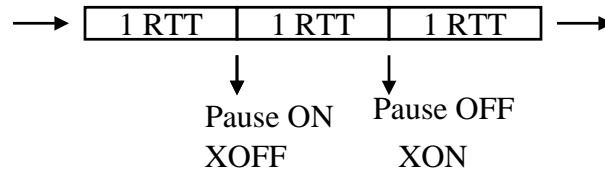

Sensitivity Analysis

- ❑ All configurations analyzed so far used same parameter values, except for N_0 .
- ❑ How N_0 affects the scheme?
- ❑ Continuous traffic, $N_0=100, 80, 40, 20$

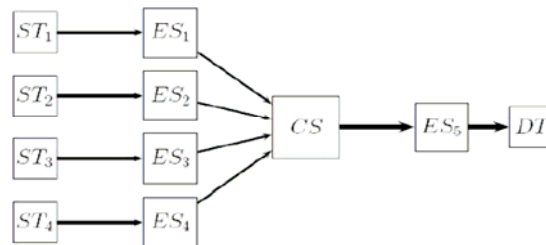

N0=100

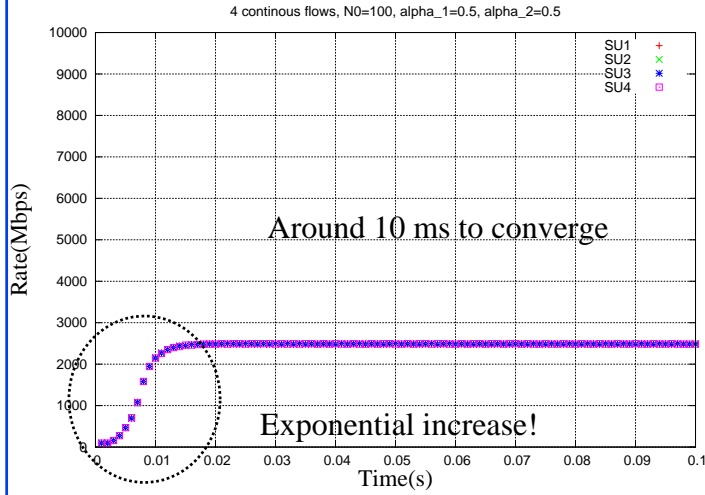

Washington University in Saint Louis

IEEE 802.11a March 13-15, 2007

Raj Jain

51

N0=80

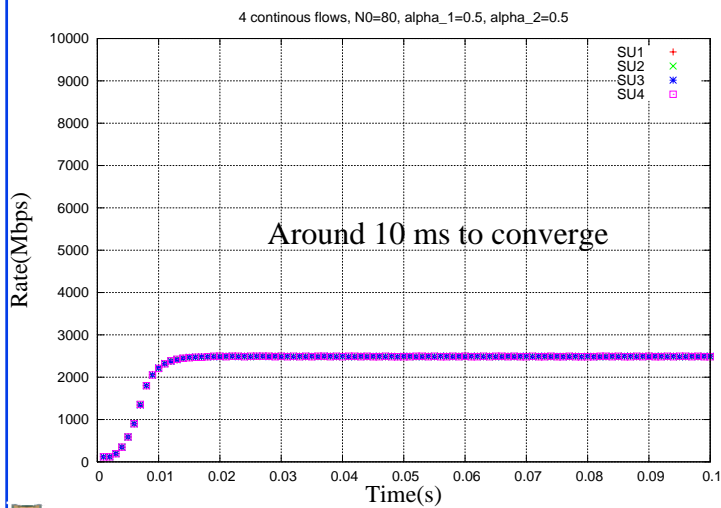

Washington University in Saint Louis

IEEE 802.11a March 13-15, 2007

Raj Jain

52

N0=40

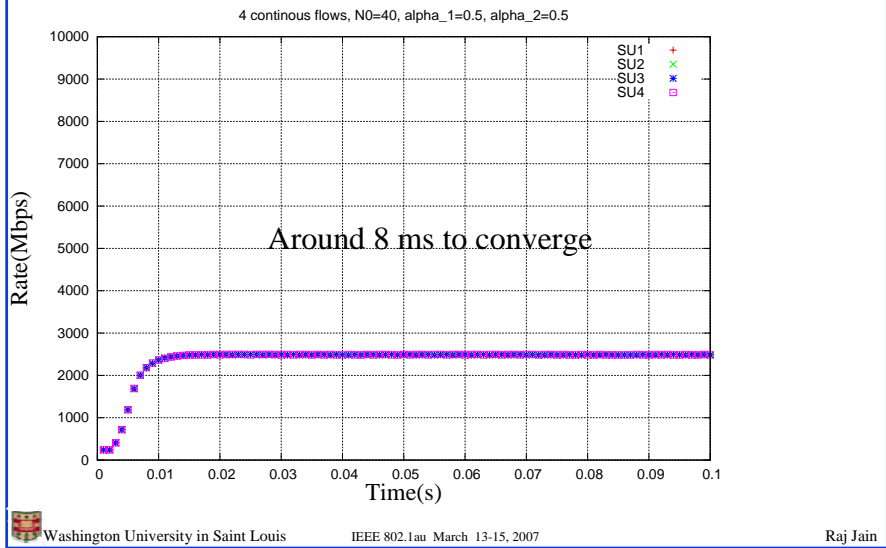

53

N0=20

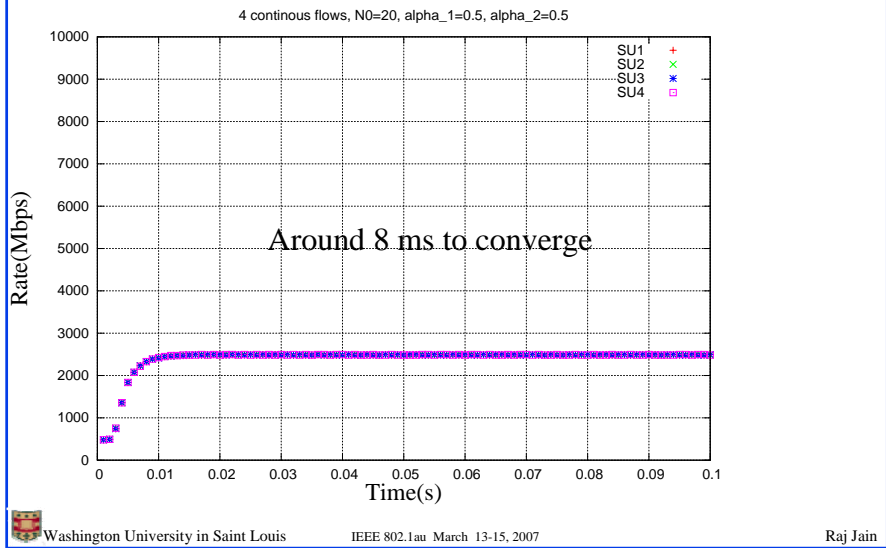

54

Sensitivity to N0

- The limited rate increase results in a logarithmic rise

$$\text{Convergence time to go from } N_0 \text{ to } N = \log_{\lambda} \left(\frac{N_0}{N} \right)$$

Here λ is the multiplier used in limited increase

So now N_0 does not have a significant effect. It can be set to a large value.



Overhead of FECN

- Given the configuration of the network, FECN has almost deterministic overhead
- Each flow generates one tag every T interval.
- For N flows in a simulation of duration t:
 - $t \cdot N / T$ FECN tags are added to forward data packets
 - $t \cdot N / T$ FECN control messages returned by the destinations
- Alternative designs where T is dynamically varied depending upon the stability, load, or rate were tried successfully but deemed unnecessary. A simple two T strategy consists of using a larger T if the system is operating near optimal region.
- It is also possible to use count based rate discovery, where every nth packet is tagged. This works but convergence to fairness takes slightly longer.



Advantages of FECN

- Flexibility:
 - Switches can base rates on resources other than one queue, e.g., sum of input and output queues, utilization of shared buffers, # of channels available on a wireless link, etc.
 - Switches can give different rate to a flow based on traffic type, class of service, types of sources, VLANs
- Works perfectly on variable link speeds, e.g., wireless links
- Vendor differentiation



Summary

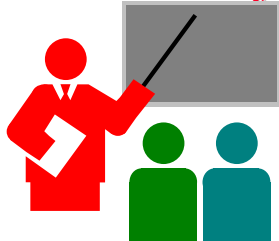

1. Convergence of rates is very fast
2. Convergence time is a small multiple of measurement interval T
3. Convergence to fairness is built in. All active sources get the same rate.
4. **Bursty traffic** can be supported and can get fair and efficient allocation due to fast convergence



Summary (Cont)

5. RD tags in the packets are simple – just rates, RLQ ID, and direction.
6. Source algorithm is quite simple
7. Switch enhancements minimize queue buildup and avoid the need for PAUSE
8. No internal parameters or details of the switch are shared outside with the sources \Rightarrow Switch algorithms and parameters can be easily changed
9. Very few parameters: T
10. Parameters are easy to set.
11. Scheme not very sensitive to parameters
12. Potential for vendor differentiation for switch algorithms.



References

- Bobby Vandalore, Raj Jain, Rohit Goyal, Sonia Fahmy, "Dynamic Queue Control Functions for ATM ABR Switch Schemes: Design and Analysis," Computer Networks, August 1999, Vol. 31, Issue 18, pp. 1935-1949.
http://www.cse.wustl.edu/~jain/papers/cnis_qctrl.htm

