

Wireless Cellular Networks: 3G

Raj Jain
Washington University
Saint Louis, MO 63131
Jain@cse.wustl.edu

These slides are available on-line at:

<http://www.cse.wustl.edu/~jain/cse574-06/>



- ❑ Wireless Generations: 1G, 2G, 2.5G, 3G
- ❑ CDMA
- ❑ GSM
- ❑ CDPD
- ❑ GPRS, EDGE
- ❑ EV-DV, EV-DO
- ❑ WCDMA, CDMA2000, TD-SCDMA
- ❑ HSDPA

3G Technologies

- ❑ Wideband CDMA (W-CDMA): Next Generation GSM. Uses 5 MHz channel width \Rightarrow 2 Mbps
- ❑ CDMA2000: Next Generation CDMA (IS-95)
1.25 MHz Channels \Rightarrow 144 kbps
- ❑ 3x, 6x, 9x, and 12x in future
- ❑ 3x (3XRTT): 3.75 MHz channel \Rightarrow 2 Mbps
- ❑ UWC-136: Next Generation TDMA (IS-136)
200 kHz Channels \Rightarrow 384 kbps or
1.6 MHz Channels \Rightarrow 2 Mbps
Developed by Universal Wireless Communications Consortium (UWCC)
- ❑ Goal: Provide high-speed packet based Voice and Data

3G

- ❑ Also known as ITU IMT-2000 Project.
Started in 1980.
- ❑ Goal: To have one world-wide standard and a common frequency band for mobile networking
- ❑ Result:
 - Three frequency bands: Below 1 GHz, 1.7GHz, 2.5GHz
 - Three different technologies: W-CDMA (Europe) CDMA2000 (North America) , and TD-SCDMA in China.

WCDMA

- ❑ Wideband CDMA
- ❑ Proposed by European Telecom Std Inst (ETSI) Alpha group
- ❑ WCDMA has 5MHz single carrier system w Freq Div Duplexing and direct sequence (FDD-DS) \Rightarrow 2 Mbps data
- ❑ 3rd Generation Partnership Project (3GPP.org)
- ❑ 2.5G:
 - HSCSD (High-Speed Circuit Switched Data)
 - GPRS (General Packet Radio Service)
144 kbps data only
 - EDGE (Enhanced Data for GSM Evolution)
384 kbps data
 - HSDPA (High-speed downlink packet access)
Asymmetric. 2 Mbps+ downlink.

CDMA2000

- ❑ Proposed by Third Generation Partnership Project 2 (3GPP2.org).
- ❑ 3GPP2: Partnership of 5 Telecom standards bodies: ARIB and TTC in Japan, CWTS in China, TTA in Korea and TTA in North America
- ❑ Full backward compatibility with IS-95B (CdmaOne)
- ❑ CDMA2000 is also known as CDMA-MC (multi-carrier)
- ❑ It uses n carriers of 1.2288 MHz each. 1x, 3x, 6x, 9x, 12x
- ❑ 2.5G: Operators can overlay CDMA2000 1x now over CdmaOne. Also known as CDMA2000 1xEV. Implemented in 2 steps:
 - 1xEV-DO (Evolution data only),
 - 1xEV-DV (Evolution data and voice on one carrier).

TD-SCDMA

- ❑ Time Division Synchronous CDMA
- ❑ Proposed by China Wireless Telecommunication Standards group (CWTS)
- ❑ Uses Time Division Duplex (TDD)
- ❑ Synchronous \Rightarrow All base station clocks are synchronized
- ❑ <http://www.tdscdma-forum.org/>

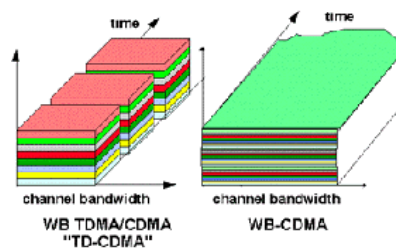

Washington University in St. Louis

CSE574s

©2006 Raj Jain

7-7

2.5 G

Data services over 2G networks

- ❑ GSM
 - High-speed circuit-switched data (HSCSD)
 - General Packet Radio Service (GPRS)
 - Enhanced Data Rate for GSM Evolution (EDGE)
- ❑ CdmaOne:
 - 1xEV-DO
 - 1xEV-DV

Washington University in St. Louis

CSE574s

©2006 Raj Jain

7-8

HSCSD

- ❑ High-Speed Circuit Switched Data (HSCSD)
- ❑ First attempt to get high-speed data over GSM
- ❑ Allows data users to get 1 to 8 slots
Data rates up to 115 kbps
- ❑ Circuit switched \Rightarrow Constant data rate
Not suitable for bursty data
Not widely implemented
GPRS is more widely implemented

GPRS

- ❑ General Packet Radio Service (GPRS)
- ❑ Standard GSM has 8 slots per 200 kHz channel
 \Rightarrow 9.6 kbps data
- ❑ GPRS allows any number of slots to a user
 - 4 different codings used depending upon channel condition
 - 9.05 kbps to 21.4 kbps per slot
 - 76-171 kbps using all 8 slots.
- ❑ GPRS user can hop channels (as in CDPD). 2.5G Technology

G_i = GSM User

G_{pi} = GPRS User

	t_0	t_1	t_2	t_3	t_4	t_5	t_6	t_7	t_0	t_1	t_2
Uplink 1	G1		G2		GP2			GP1	G1		G2
Uplink 2				GP1			GP2				
Downlink 1	G1	GP1	G2		GP2			GP1	G1		G2
Downlink 2	GP1				GP1					GP2	

GPRS (Cont)

- ❑ Supports intermittent and bursty data transfers
Point-to-multipoint also supported
- ❑ Need to add two new elements to GSM networks:
 - Service GPRS support node (SGSN)
 - Security, Mobility, Access control
 - Gateway GPRS support node (GGSN)
 - Connects to external packet switched networks
- ❑ Standardized by ETSI

EDGE

- ❑ Enhanced Data Rates for GSM Evolution (EDGE)
- ❑ Standard GSM uses Gaussian Minimum Shift Keying (GMSK) modulation
- ❑ EDGE changes to 8-PSK modulation \Rightarrow 3 bits/Hz
- ❑ GPRS+EDGE \Rightarrow 384 kbps
- ❑ Need better radio signal quality
- ❑ 76 mobile network operators in 50 countries have committed to deploy EDGE (March 2004)
http://www.gsacom.com/news/gsa_158.php4

Data Rates

Technology	Bandwidth	Data Rate/User (Theory)	Data Rate/User (Realistic)
GSM	200 kHz	9.6 kbps	9.6 kbps
GPRS	200 kHz	172 kbps	40 kbps
EDGE	200 kHz	474 kbps	100 kbps
CDMA2000 3x	3.75 MHz	2 Mbps	384 kbps
WCDMA	5 MHz	2 Mbps	1 Mbps

HSDPA

- ❑ High-Speed Downlink Packet Access for WCDMA
- ❑ Improved spectral efficiency for downlink \Rightarrow Asymmetric
- ❑ Up to 10 Mbps in theory, 2Mbps+ in practice
- ❑ Announced by Siemens, then by Ericsson, Alcatel, Fujitsu
- ❑ Adaptive modulation and coding (AMC)
- ❑ Multi-code (multiple CDMA channels) transmission
- ❑ Fast physical layer (L1) hybrid ARQ (H-ARQ)
- ❑ Packet scheduler moved from the radio network controller (RNC) to the Node-B (base station)
 - \Rightarrow advanced packet scheduling techniques
 - \Rightarrow user data rate can be adjusted to match the instantaneous radio channel conditions.

1xEV-DV

- ❑ 1x Evolution to Data and Voice (1xEV-DV)
- ❑ Single 1.25 MHz bandwidth shared between voice and data users
- ❑ 3.1 Mbps peak data rate on Forward Packet Data Channel
- ❑ Voice users are usually scheduled first
- ❑ Dynamic allocation of the unused BS power to data users every slot cycle (1.25 ms)

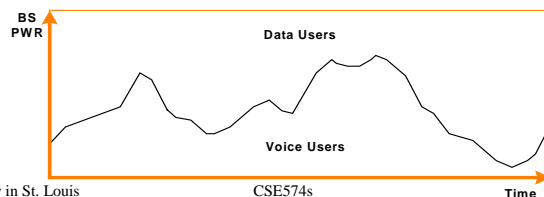

Washington University in St. Louis

CSE574s

©2006 Raj Jain

7-15

1xEV-DV vs. 1xEV-DO

- ❑ EV-DV uses 1 RF channel for data and voice while EV-DO requires separate carrier frequencies
- ❑ Fully compatible with CdmaOne and CDMA2000 allowing all types of handoff between those systems \Rightarrow economical, incremental deployment; uninterrupted voice and data coverage
- ❑ EV-DV provides smooth coexistence between voice and data services
- ❑ IS-2000 Rel 0 BS can be upgraded to support EV-DV Rel C by addition of channel card and SW upgrade
- ❑ To upgrade the same BS to support EV-DO in addition to 1x, a separate RF path (from antennas through PA's to channel card) is needed

Washington University in St. Louis

CSE574s

©2006 Raj Jain

7-16

Data Rates

	Down Link	Up Link
1x	9.6 kbps – 614.4 kbps	9.6 kbps – 460.8 kbps
1xEV-DV Rel. C	9.6 kbps – 3.09 Mbps	9.6 kbps – 460.8 kbps
1xEV-DV Rel. D	9.6 kbps – 3.09 Mbps	9.6 kbps – 1.5 Mbps
1xEV-DO	38.4 kbps – 2.45 Mbps	9.6 kbps – 450.8 kbps
1xEV-DO Rel. A	38.4 kbps – 2.45 Mbps	9.6 kbps – 1.5 Mbps

3G Deployments



- ❑ 3G deployments are finally happening.
- ❑ 18 Deployments by mid-2005
- ❑ UMTS forum lists a few dozen installations
Ref: http://www.umts-forum.org/servlet/dycon/ztumts/umts/Live/en/umts/Resources_Deployment_index
- ❑ Mostly in Japan and Korea
- ❑ NTT DoCoMo uses W-CDMA for its 3G service
- ❑ Deployments starting in Brazil, Canada, Japan, Korea, USA, and UK (2004)

Evolution of Cellular Technologies

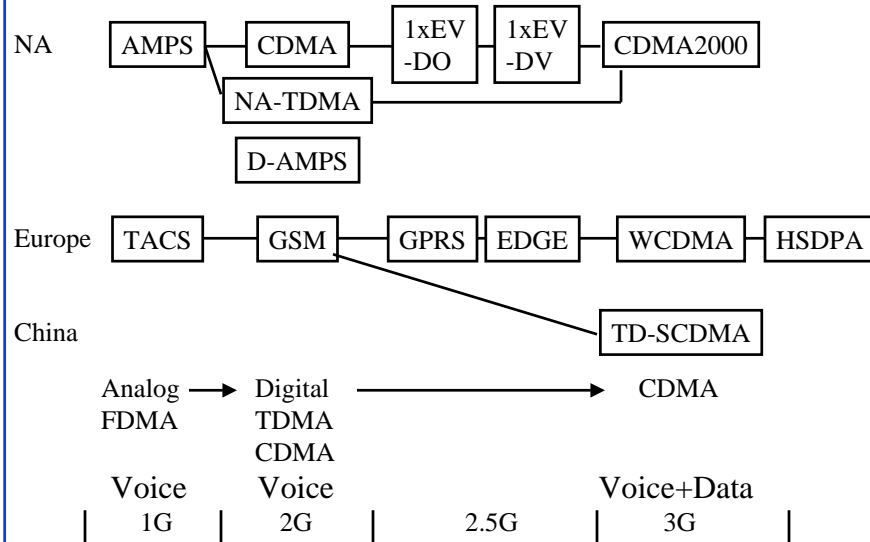

Washington University in St. Louis

CSE574s

©2006 Raj Jain

7-19

Summary

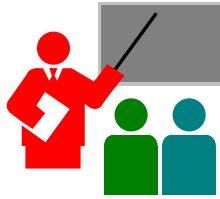

- ❑ Geometry of cells and frequency reuse
- ❑ Fading, diffraction, scattering, multi-path
- ❑ Three generations: 1G (Analog), 2G (digital), 3G (Data)
- ❑ AMPS
- ❑ IS-95
- ❑ IMT2000 (W-CDMA, CDMA2000, TD-SCDMA)

Washington University in St. Louis

CSE574s

©2006 Raj Jain

7-20

Reading Assignment

- Read sections 3.1 to 3.6 from Murthy and Manoj