

Hashes and Message Digests

Raj Jain
Washington University in Saint Louis
Saint Louis, MO 63130
Jain@cse.wustl.edu

Audio/Video recordings of this lecture are available at:
<http://www.cse.wustl.edu/~jain/cse571-07/>



- One-Way Functions
- Birthday Problem
- Probability of Hash Collisions
- Authentication and encryption using Hash
- Sample Hashes: MD2, MD4, MD5, SHA-1, SHA-2
- HMAC

One-Way Functions

□ Hash = Message Digest

= one way function

- Computationally infeasible to find the input from the output
- Computationally infeasible to find the two inputs for the same output

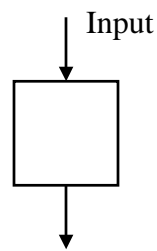

One-Way Functions (Cont)

- Easy to compute but hard to invert
- If you know both inputs it is easy to calculate the output
- It is unfeasible to calculate any of the inputs from the output
- It is unfeasible to calculate one input from the output and the other input

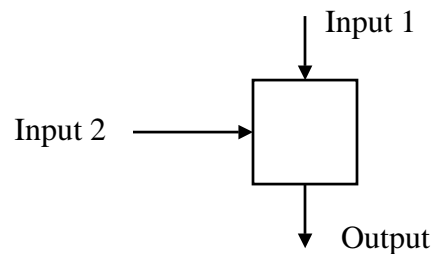

Examples of Hash Functions

- ❑ MD2 = Message Digest 2 [RFC 1319] - 8b operations
- ❑ Snefru = Fast hash named after Egyptian king
- ❑ MD4 = Message Digest 4 [RFC 1320] - 32b operations
- ❑ Snefru 2 = Designed after Snefru was broken
- ❑ MD5 = Message Digest 5 [RFC 1321] - 32b operations
- ❑ SHA = Secure hash algorithm [NIST]
- ❑ SHA-1 = Updated SHA
- ❑ SHA-2 = SHA-224, SHA-256, SHA-384, SHA-512
SHA-512 uses 64-bit operations
- ❑ HMAC = Keyed-Hash Message Authentication Code

Birthday Problem

- ❑ What is the probability that two people have the same birthday (day and month)

K	Total	Different
2	365^2	365×364
3	365^3	$365 \times 364 \times 363$
		...
k	365^k	$365 \times 364 \times 363 \times \dots \times (365 - k + 1)$

$$\begin{aligned} P(\text{No common day}) &= \frac{365 \times 364 \times 363 \times \dots \times (365 - k + 1)}{365^k} \\ &= \frac{365!}{365^k (365 - k)!} \end{aligned}$$

Birthday Problem (Cont)

- With 22 people in a room, there is better than 50% chance that two people have a common birthday
- With 40 people in a room there is almost 90% chance that two people have a common birthday
- If there k people, there are $k(k-1)/2$ pairs

$$P(\text{1 pair having common birthday}) = \frac{k(k-1)}{2 \times 365}$$

$$k \geq \sqrt{365} \Rightarrow P > 0.5$$

- In general, n possibilities
 $\Rightarrow \sqrt{n}$ trials to find a collision

k	P
2	.01
3	.02
4	.03
...	...
19	.41
20	.44
21	.48
22	.51
23	.54
...	...
38	.88
39	.89
40	.90

Probability of Hash Collisions

- Arbitrary length message \Rightarrow Fixed length hash
 \Rightarrow Many messages will map to the same hash
- Given 1000 bit messages $\Rightarrow 2^{1000}$ messages
- 128 bit hash $\Rightarrow 2^{128}$ possible hashes
 $\Rightarrow 2^{1000}/2^{128} = 2^{872}$ messages/hash value
- n -bit hash \Rightarrow Need avg $2^{n/2}$ tries to find two messages with same hash
- 64 bit hash $\Rightarrow 2^{32}$ tries (feasible)
- 128 bit hash $\Rightarrow 2^{64}$ tries (not feasible)

Authentication using Hash

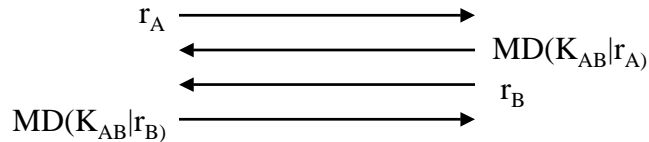

- ❑ Anyone can compute $MD(m)$
⇒ Need to send shared secret K_{AB}
- ❑ Message is split in to blocks.
Digest of n-1 is used with block n
- ❑ Issue: Anyone can append to the message
- ❑ Solution:
 - Put shared secret at the end
 - Send only part of the MAC
 - Put shared secret at both front and back ⇒ Keyed Hash

Encryption Using Hash

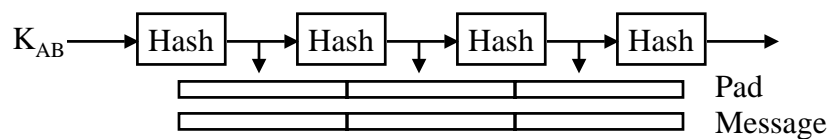

- ❑ Use shared secret to generate hash
- ❑ Continually hash the hash to generate one-time pad
- ❑ XoR the pad to message
- ❑ Issue: If some one knows the plain text, they can compute the pad and use it to send another message
- ❑ Solution:
 - Use IV
 - Use cipher block chaining

Encryption Using Hash (Cont)

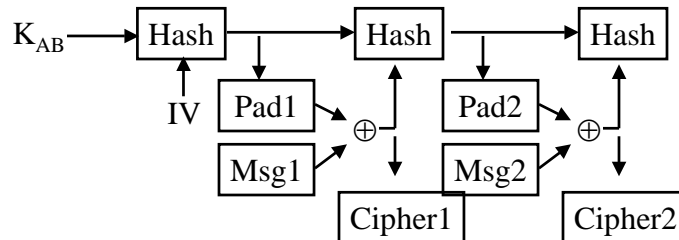

Hash Using Encryption

- ❑ Use the message as a key to encrypt a constant
- ❑ Unix Password Hash
 - ASCII 7-bits of 8 characters are used as 56bit DES key
- ❑ Issue: Can hash a large number of words and see if anyone matches from a set
- ❑ Solution: Use a different IV
 - Hash(IV|password).
 - IV is stored in clear.
 - IV = Salt

Hashing Large Messages

- Break the message in to fixed size blocks

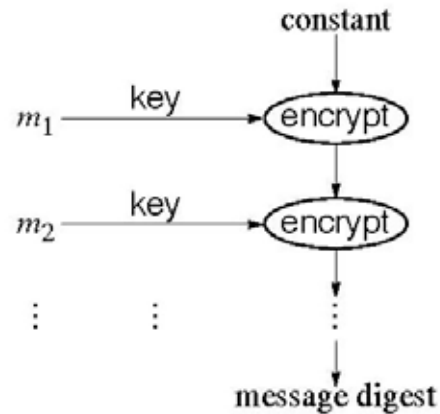

Hashing Large Messages (Cont)

- Issue: DES produces 64-bit digest $\Rightarrow 2^{32}$ tries to find collision
- Solution:
 - 1. Xor with input in each round
 - 2. Get 128 bit using DES twice - forward, reverse

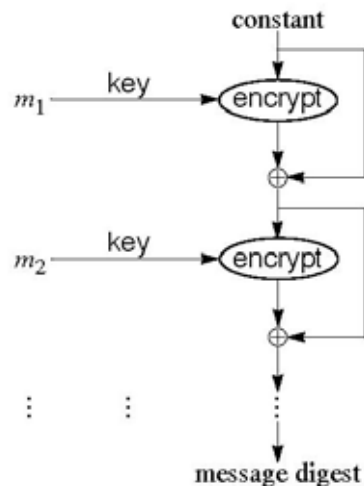

MD2 Hash

- ❑ Produces 128-bit hash using 128 bit blocks
- ❑ Designed by Ron Rivest in 1989
- ❑ Described in RFC 1319
- ❑ Used in certificates generated with MD2 and RSA
- ❑ Examples:
 - MD2("The quick brown fox jumps over the lazy dog")
= 03d85a0d629d2c442e987525319fc471
 - MD2("The quick brown fox jumps over the lazy cog")
= 6b890c9292668cdbbfda00a4ebf31f05

MD2 Algorithm Steps

1. Padding: Message is padded to make it $16n$ octets.
 2. Checksum: A 16 octet checksum is computed and appended
 3. Final Pass: $16(n+1)$ octets are hashed using 18 rounds
- ❑ Padding: padded bytes contain length of pad
Always pad (even if a multiple of 16).

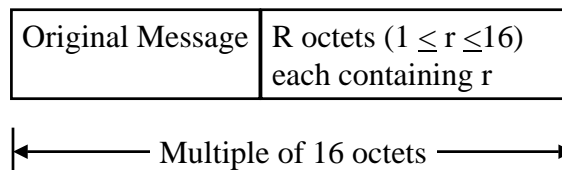

Why Always Pad?

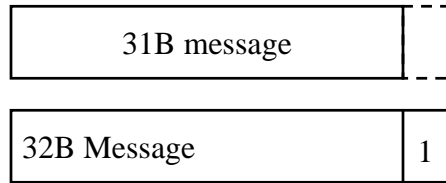

- ❑ Message 1 is not a multiple of 16 and so it is padded with 15 in 15 bytes
- ❑ Message 2 is a multiple of 16 but contains 15
- ❑ If message 2 is not padded, both these messages will have hash. \Rightarrow It is trivial to find collision.

MD2 Checksum

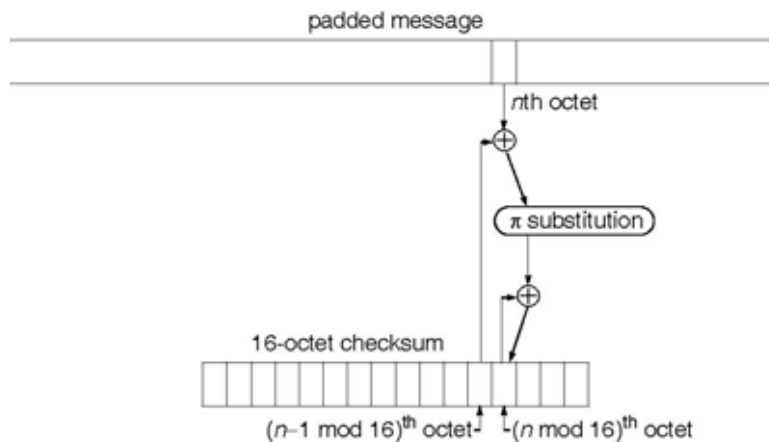

MD2 π Substitution Table

41	46	67	201	162	216	124	1	61	54	84	161	236	240	6	19
98	167	5	243	192	199	115	140	152	147	43	217	188	76	130	202
30	155	87	60	253	212	224	22	103	66	111	24	138	23	229	18
190	78	196	214	218	158	222	73	160	251	245	142	187	47	238	122
169	104	121	145	21	178	7	63	148	194	16	137	11	34	95	33
128	127	93	154	90	144	50	39	53	62	204	231	191	247	151	3
255	25	48	179	72	165	181	209	215	94	146	42	172	86	170	198
79	184	56	210	150	164	125	182	118	252	107	226	156	116	4	241
69	157	112	89	100	113	135	32	134	91	207	101	230	45	168	2
27	96	37	173	174	176	185	246	28	70	97	105	52	64	126	15
85	71	163	35	221	81	175	58	195	92	249	206	186	197	234	38
44	83	13	110	133	40	132	9	211	223	205	244	65	129	77	82

- 0 is replaced by 41. 1 is replaced by 46
- Based on digits of π

Final Pass

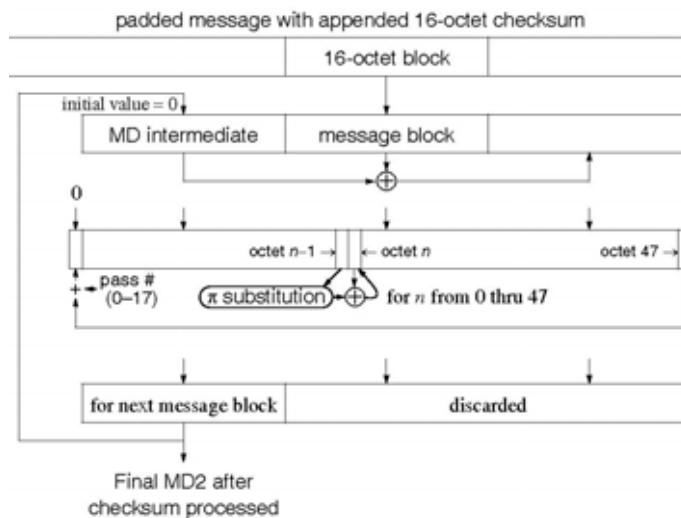

- 16 bytes at a time. 16 bytes are expanded to 48 bytes.

MD2 Insecurity

- ❑ 2004: Shown to have 2^{104} time complexity (rather than 2^{128})

MD4 Hash

- ❑ 128 bit hash using 512 bit blocks using 32-bit operations
- ❑ Invented by Ron Rivest in 1990
- ❑ Described in RFC 1320
- ❑ A variant of MD4 is used in eDonkey200/eMule P2P Networks in their ed2k URI scheme
 - Files with the same content get the same ID even if different names or location
 - ed2k://file|The_Two_Towers-The_Purist_Edit-Trailer.avi|14997504|965c013e991ee246d63d45ea71954c4d|/

MD4 Algorithm

□ 1. Padding

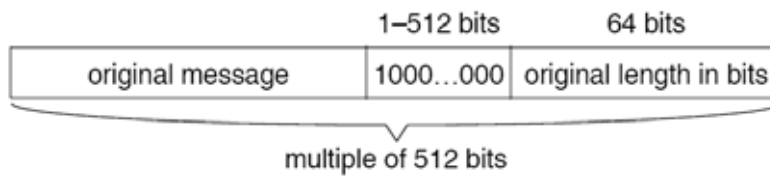

MD4 Overview

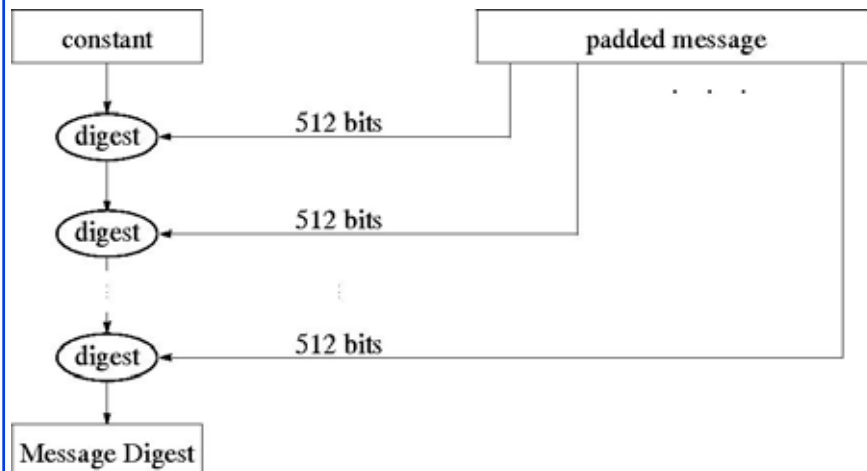

- $f(512\text{-bit message block} + 128\text{-bit Digest}) \rightarrow 128\text{ bit Digest}$
- Three passes of 16 operations each over the message block

MD4 Overview

- ❑ Uses non-linear function, modular addition, and left rotation
- ❑ Different functions are used in each pass
 - 1. Selection: $F(x,y,z) = (x \wedge y) \vee (\neg x \wedge z)$
 - 2. Majority: $G(x,y,z) = (x \wedge y) \vee (x \wedge z) \vee (y \wedge z)$
 - 3. XOR: $H(x,y,z) = x \oplus y \oplus z$
- ❑ Different rotations are used for each word
 - 3, 7, 11, 15 bit rotations in the first pass
 - 3, 5, 9, 13 bit rotations in the 2nd pass
 - 3, 9, 11, 15 bit rotations in the 3rd pass
- ❑ Constants are added in Pass 2 and 3

MD4 Insecurity

- ❑ 2004: MD4 collisions can be generated by hand or 5 seconds on a computer

MD5 Hash

- ❑ 128-bit hash using 512 bit blocks using 32-bit operations
- ❑ Invented by Ron Rivest in 1991
- ❑ Described in RFC 1321
- ❑ Commonly used to check the integrity of files (easy to fudge message and the checksum)
- ❑ Also used to store passwords

MD5 Algorithm

- ❑ 4 passes of 16 operations each over the message block
- ❑ Uses non-linear function, modular addition, and left rotation

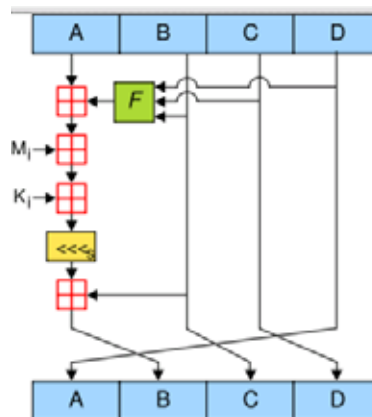

[Source:Wikipedia]

MD5 Algorithm (Cont)

- Different functions are used in each pass

$$F(X, Y, Z) = (X \wedge Y) \vee (\neg X \wedge Z)$$

$$G(X, Y, Z) = (X \wedge Z) \vee (Y \wedge \neg Z)$$

$$H(X, Y, Z) = X \oplus Y \oplus Z$$

$$I(X, Y, Z) = Y \oplus (X \vee \neg Z)$$

\wedge, \vee, \neg denote AND, OR, and complement

- Different rotations are used for each word

MD5 Insecurity

- 1993: Two different IV produce the same digest
- 1996: Collision of the compression function
- 2004: a distributed project was done to crack MD5 using birthday attack
- Aug 2004: collisions were found in 1 hour on IBM P690
- March 2005: collisions within a few hours on a single notebook
- March 2006: collisions within 1 minute on a single notebook
- "Rainbow Tables" are available on the Internet to crack MD5

Secure Hash Algorithm (SHA)

- ❑ Successor to and similar to MD5
- ❑ SHA-0: FIPS PUB 180, 1993. Withdrawn shortly after publ.
- ❑ SHA-1: FIPS PUB 180-1, 1995. 160 bit hash
- ❑ SHA-2: FIPS PUB 180-2, 2002
 - SHA-224
 - SHA-256
 - SHA-384
 - SHA-512
- ❑ SHA-1 is used in TLS, SSL, PGP, SSH, S/MIME, and IPsec
 - Required by law in US Govt applications
 - Used in Digital Signature Standard
- ❑ Pseudo-codes for SHA algorithms are available.
- ❑ NIST certifies implementations.

SHA-1 Algorithm

- ❑ 160 bit hash using 512 bit blocks and 32 bit operations
- ❑ Five passes (4 in MD5 and 3 in MD4)
- ❑ Maximum message size is 2^{64} bit
- ❑ 512 bits are expanded to 5×512 bits:
 - n^{th} word = xor of $n-3$, $n-8$, $n-14$, and $n-16$
- ❑ In SHA-1 these words are rotated left by one bit before xor
- ❑ Total 80 words: W_0, \dots, W_{79}

SHA-1 Algorithm (Cont)

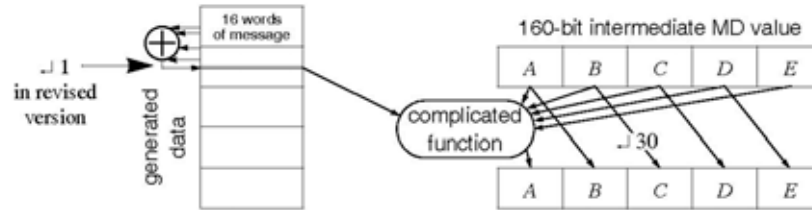

SHA Insecurity

- ❑ SHA-0:
 - 1998: Time complexity of SHA-0 was shown to be 2^{61} compared to 2^{80}
 - 12 Aug 2004: Collision for SHA-0 with 2^{51} complexity
 - 17 Aug 2004: Collision for SHA-0 with 2^{40}
 - Feb 2005: 2^{39}
- ❑ SHA-1:
 - Will be phased out by 2010 by SHA-2
 - Feb 2005: 2^{69} operations in stead of 2^{80}
 - 17 Aug 2005: 2^{63} for finding a collision
 - 2^{35} compression fn evaluations for 64-round SHA-1

SHA-2

- ❑ SHA-256 uses 32-bit operations
- ❑ SHA-512 uses 64-bit operations
- ❑ Use different shift amounts and additive constants
- ❑ SHA-224 and SHA-384 are simply truncated versions of SHA-256 and SHA-512 using different initial values.
- ❑ SHA-224 matches the key length of two-key triple-DES

Algorithm	Output size (bits)	Internal state size (bits)	Block size (bits)	Max message size (bits)	Word size (bits)	Rounds	Operations	Collision
SHA-0	160	160	512	$2^{64} - 1$	32	80	+,and,or,xor,rotl	Yes
SHA-1	160	160	512	$2^{64} - 1$	32	80	+,and,or,xor,rotl	2^{63} attack
SHA-256/224	256/224	256	512	$2^{64} - 1$	32	64	+,and,or,xor,shr,rotr	None yet
SHA-512/384	512/384	512	1024	$2^{128} - 1$	64	80	+,and,or,xor,shr,rotr	None yet

[Source: Wikipedia]

HMAC

- ❑ Keyed-Hash Message Authentication Code
- ❑ Guarantees both data integrity and authenticity
- ❑ Can use any crypto-graphic hash function such as MD5 or SHA-1
- ❑ Described in RFC 2104
- ❑ FIPS PUB 198 generalizes and standardizes HMACs
- ❑ HMACS-MD5 and HMAC-SHA-1 are used in IPsec and TLS
- ❑ $HMAC_k(m) = h((k \oplus opad) || h((k \oplus ipad) || m))$
- ❑ Here ipad and opad are constants
- ❑ Designed to be secure provided the main compression function is secure

HMAC (Cont)

- ❑ Secure:
 1. Collision Resistance:
Can't find 2 inputs with same output
 2. If you don't know k , Cannot compute $\text{digest}(K,x)$ even if you know $\text{digest}(K,y)$ for many arbitrary y 's.
- ❑ The secret key is prepended to the message and then again to the digest

HMAC (Cont)

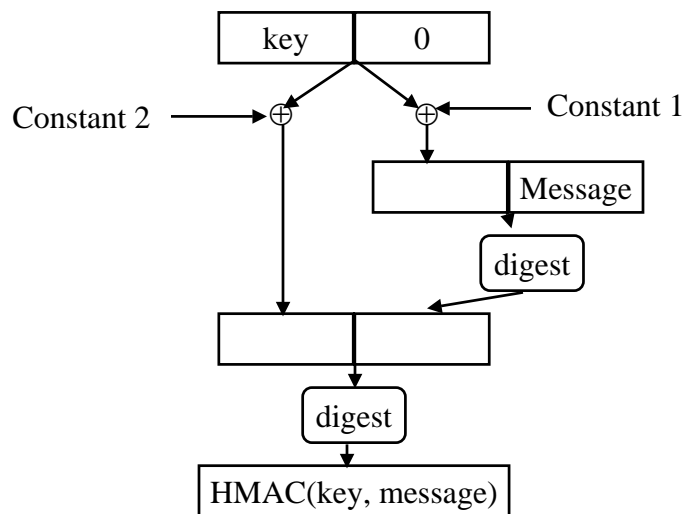

Summary

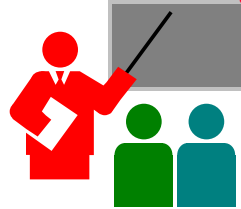

- ❑ Hashes can be used for authentication, message integrity
- ❑ Birthday attack: N-bit hash requires $2^{n/2}$ tries to find a collision
- ❑ MD4, MD5, SHA-1 consist of padding followed by multiple rounds of compression using rotation, substitution, xor, mangling functions, and constants.
- ❑ SHA-1 is currently the most secure hash. SHA-2 is coming.
- ❑ HMAC provides both authentication and integrity

References

- ❑ Chapter 5 of text book
- ❑ Wikipedia:
 - MD2, http://en.wikipedia.org/wiki/MD2_%28cryptology%29
 - MD4, <http://en.wikipedia.org/wiki/MD4>
 - MD5, <http://en.wikipedia.org/wiki/MD5>
 - SHA, <http://en.wikipedia.org/wiki/SHA-1>
 - HMAC, <http://en.wikipedia.org/wiki/HMAC>

Homework 7

- Read chapter 5 of the book
- Submit answer to Exercise 5.14
- **Exercise 5.14:** Find minimal sufficient conditions for x , y , and z that would make the following functions random:
 - $\neg x$
 - $x \text{ XOR } y$
 - $x \text{ or } y$
 - $x \text{ and } y$
 - $(x \text{ and } y) \text{ or } (\neg x \text{ and } z)$
 - $(x \text{ and } y) \text{ or } (x \text{ and } z) \text{ or } (y \text{ and } z)$
 - $\text{XOR}(x, y, z)$
 - $\text{XOR}(y, (x \text{ or } \neg z))$