

IP Switching and Label Switching

Raj Jain

Professor of Computer and Information Sciences

The Ohio State University

Columbus, OH 43210

Jain@cis.ohio-state.edu

These slides are available on-line at:

<http://www.cis.ohio-state.edu/~jain/cis788-99/>

Raj Jain



- ❑ Switching vs routing
- ❑ IP Switching (Ipsilon)
- ❑ Tag Switching (CISCO)
- ❑ Multi-protocol label switching

Routing vs Switching



- ❑ Routing: Based on address lookup. Max prefix match.
 - ⇒ Search Operation
 - ⇒ Complexity $\approx O(\log_2 n)$
- ❑ Switching: Based on circuit numbers
 - ⇒ Indexing operation
 - ⇒ Complexity $O(1)$
 - ⇒ Fast and Scalable for large networks and large address spaces
- ❑ These distinctions apply on all datalinks: ATM, Ethernet, SONET

Routing vs Switching (Cont)

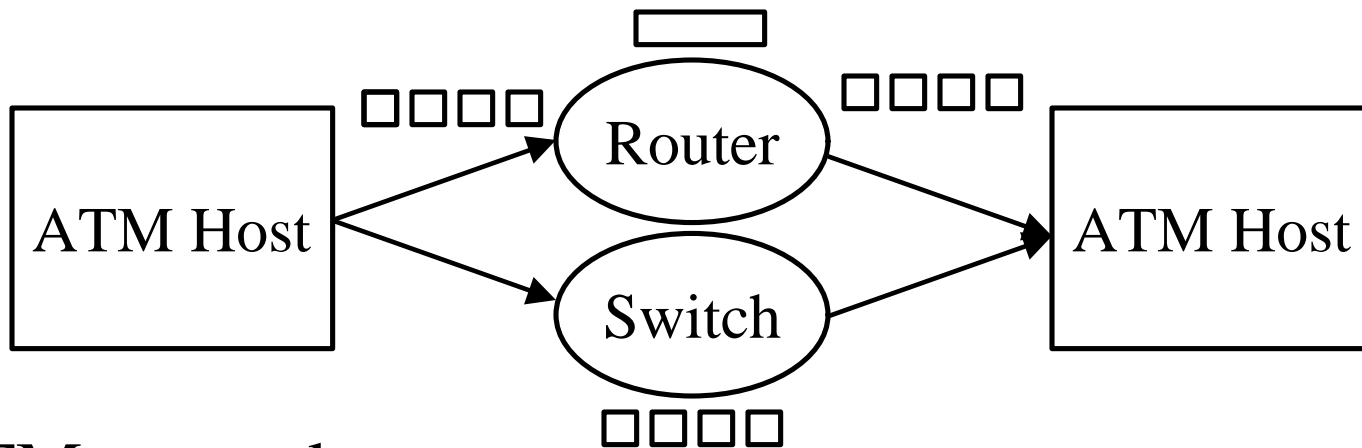

On ATM networks:

- IP routers use IP addresses
 - ⇒ Reassemble IP datagrams from cells
- IP Switches use ATM Virtual circuit numbers
 - ⇒ Switch cells
 - ⇒ Do not need to reassemble IP datagrams
 - ⇒ Fast

IP Switching

- ❑ Developed by Ipsilon
- ❑ Routing software in every ATM switch in the network
- ❑ Initially, packets are reassembled by the routing software and forwarded to the next hop
- ❑ Long term flows are transferred to separate VCs. Mapping of VCIs in the switch \Rightarrow No reassembly

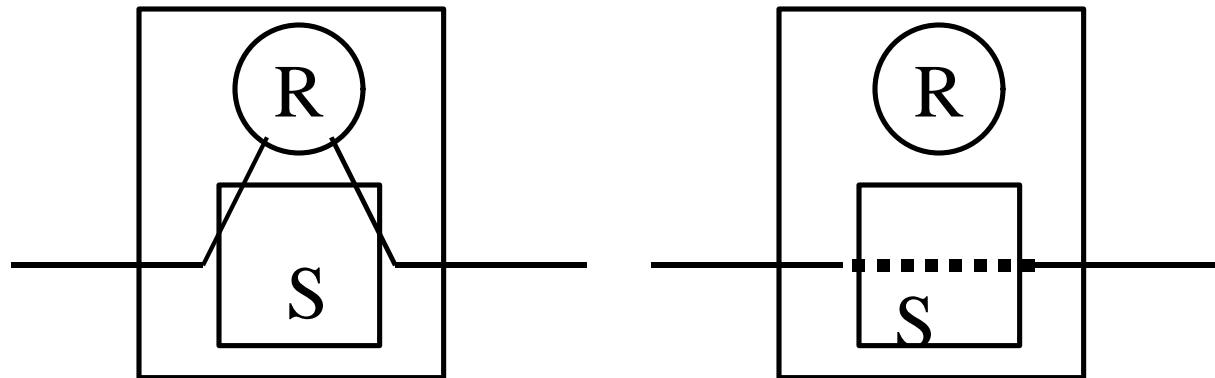

Raj Jain

IP Switching (Cont)

- ❑ Flow-oriented traffic: FTP, Telnet, HTTP, Multimedia
- ❑ Short-lived Traffic: DNS query, SMTP, NTP, SNMP, request-response
Ipsilon claimed that 80% of packets and 90% of bytes are flow-oriented.
- ❑ Ipsilon claimed their Generic Switch Management Protocol (GSMP) to be 2000 lines, and Ipsilon Flow Management Protocol (IFMP) to be only 10,000 lines of code
- ❑ Runs as added software on an ATM switch
- ❑ Implemented by several vendors

Ipsilon's IP Switching: Issues

- ❑ VCI field is used as ID.
VPI/VCI change at switch
 - ⇒ Must run on **every** ATM switch
 - ⇒ non-IP switches not allowed between IP switches
 - ⇒ Subnets limited to one switch
- ❑ Cannot support VLANs
- ❑ Scalability: Number of VC \geq Number of flows.
 - ⇒ **VC Explosion.** 1000 setups/sec.
- ❑ Quality of service determined implicitly by the flow class or by RSVP
- ❑ ATM Only

Tag Switching

- ❑ Proposed by CISCO
- ❑ Similar to VLAN tags
- ❑ Tags can be explicit or implicit L2 header



- ❑ Ingress router/host puts a tag. Exit router strips it off.

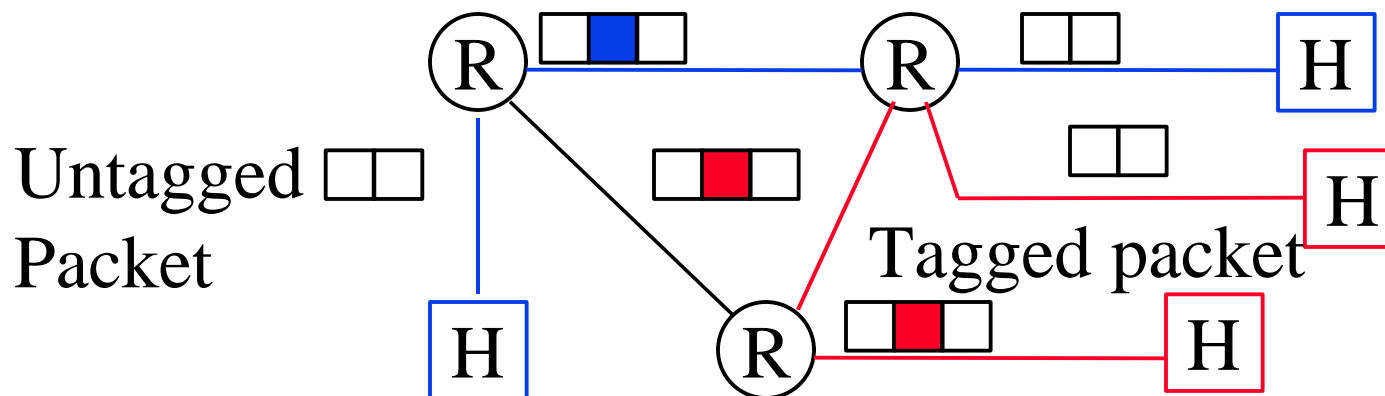

Tag Switching (Cont)

- ❑ Switches switch packets based on labels.
Do not need to look inside \Rightarrow Fast.
- ❑ One memory reference compared to 4-16
in router
- ❑ Tags have local significance
 \Rightarrow Different tag at each hop (similar to VC #)

Tag Switching (Cont)

- One VC per routing table entry

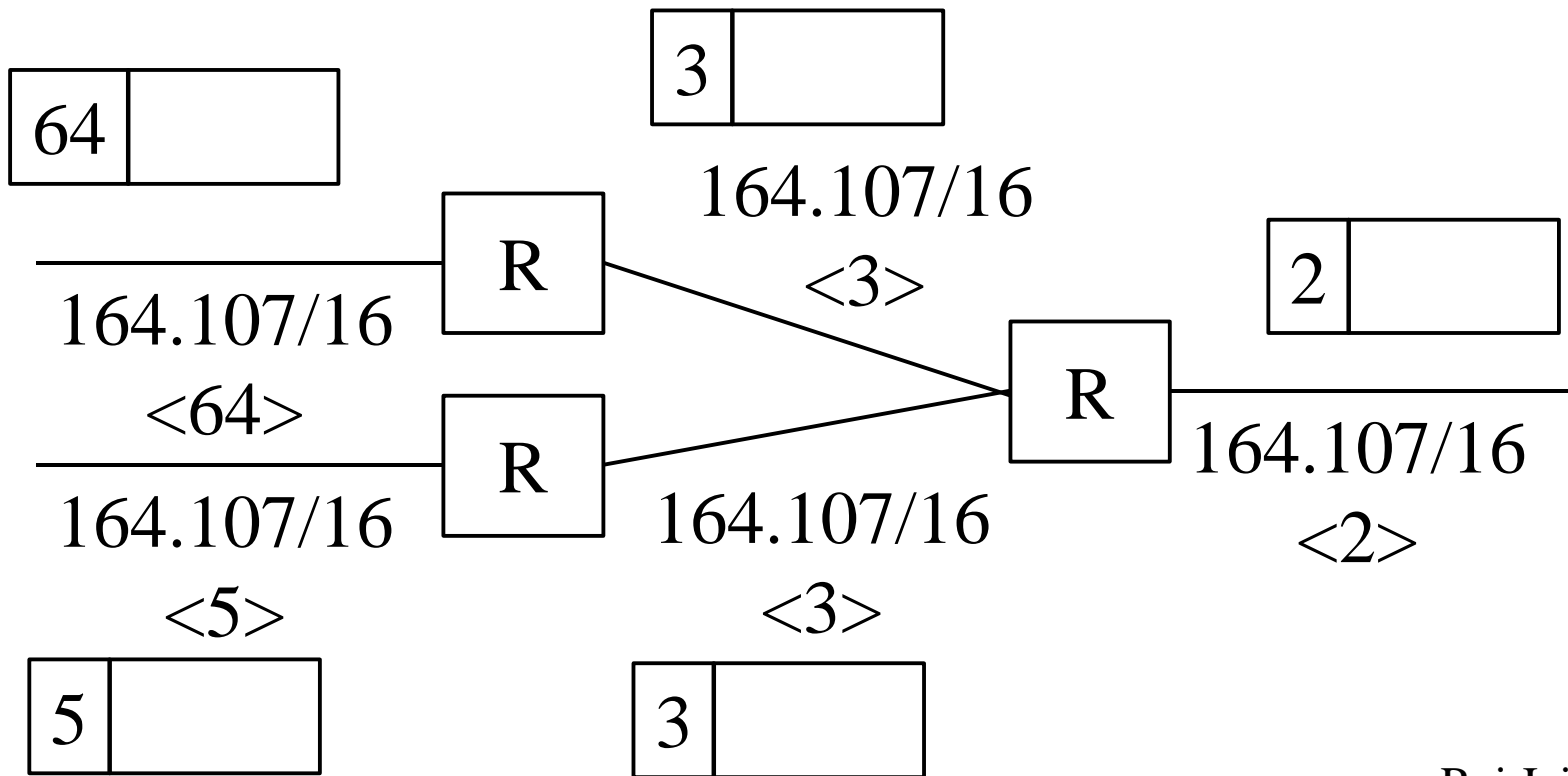

Raj Jain

Alphabet Soup

- ❑ CSR Cell Switched Router
- ❑ ISR Integrated Switch and Router
- ❑ LSR Label Switching Router
- ❑ TSR Tag Switching Router
- ❑ Multi layer switches, Swoters
- ❑ DirectIP
- ❑ FastIP
- ❑ PowerIP

MPLS

- ❑ Multiprotocol Label Switching
- ❑ IETF working group to develop switched IP forwarding
- ❑ Initially focused on IPv4 and IPv6.
Technology extendible to other L3 protocols.
- ❑ Not specific to ATM. ATM or LAN.
- ❑ Not specific to a routing protocol (OSPF, RIP, ...)

Label Stack Entry Format

- ❑ Labels = Explicit or implicit L2 header
- ❑ TTL = Time to live
- ❑ Exp = Experimental
- ❑ SI = Stack indicator

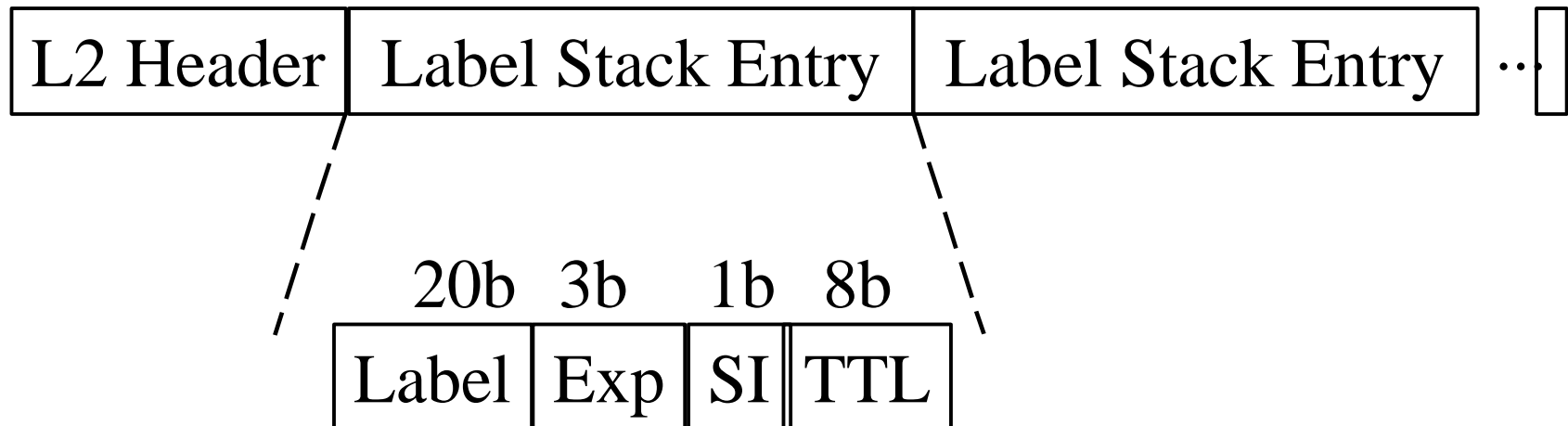

Label Stacks

- ❑ Labels are pushed/popped as they enter/leave MPLS domain
- ❑ Routers in the interior will use Interior Gateway Protocol (IGP) labels. Border gateway protocol (BGP) labels outside.
- ❑ Bottom label may indicate protocol (0=IPv4, 2=IPv6)

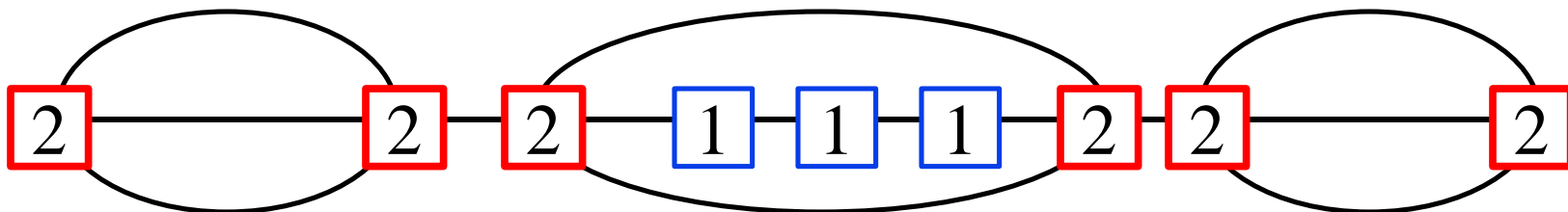
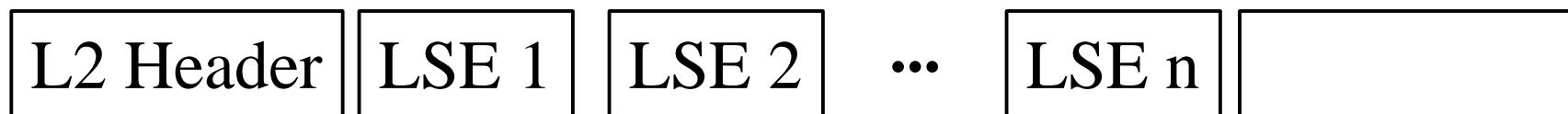
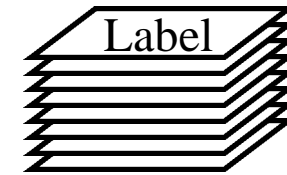

Raj Jain

Summary

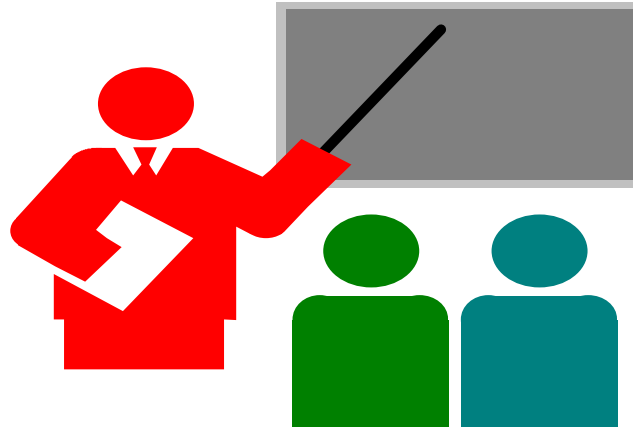

- ❑ IP Switching: Traffic-based, per-hop VCs, downstream originated
- ❑ Tag switching: Topology based, one VC per route
- ❑ MPLS combines various features of IP switching, Tag switching, and other proposals

Key References

- ❑ See http://www.cis.ohio-state.edu/~jain/refs/ipsw_ref.htm
- ❑ IP switching, http://www.cis.ohio-state.edu/~jain/cis788-97/ip_switching/index.htm
- ❑ Multiprotocol Label Switching (mpls) working group at IETF. Email: mpls-request@cisco.com