

Protocols for Multimedia on the Internet

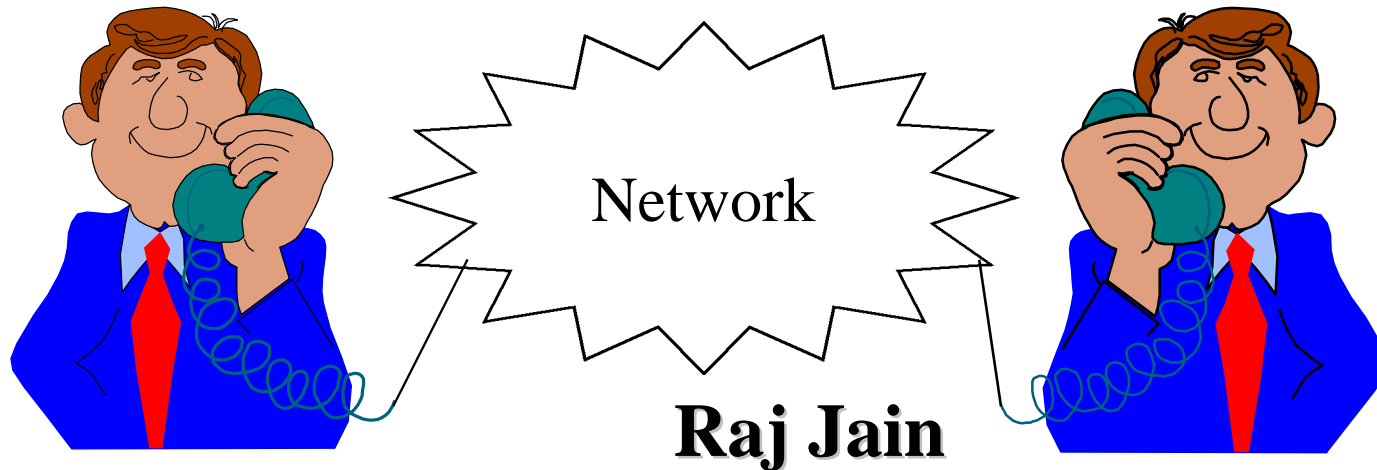

Raj Jain
The Ohio State University
Columbus, OH 43210
Jain@CIS.Ohio-State.Edu

<http://www.cis.ohio-state.edu/~jain/cis788-97/>

Email questions to question@netlab.ohio-state.edu



- ❑ Integrated services
- ❑ Resource Reservation Protocol: RSVP
- ❑ Real-time Transport Protocol: RTP, RTCP
- ❑ Real-Time Streaming Protocol: RTSP
- ❑ Multicast Backbone: MBONE, SDP
- ❑ Connection-oriented IP: ST2+

Note: Multicasting protocols were covered in the last class.

Multimedia on the Internet

- ❑ Specify source traffic requirements
- ❑ Protocols to create and maintain resource reservations
- ❑ Routing protocols that support QoS and multicast
- ❑ Transport protocols for error and flow control
- ❑ Access control
- ❑ Packet scheduler to provide QoS:

Multimedia on the Internet

- ❑ Specify source traffic requirements
Flow specs from INTSERV working group
- ❑ Protocols to create and maintain resource reservations: *RSVP*
- ❑ Routing protocols that support QoS and multicast
Mrouted, ST2+
- ❑ Transport protocols for error and flow control: *RTP*
- ❑ Access control: Connection *admission based on usage, packet dropping*
- ❑ Packet scheduler to provide QoS:
Weighted Fair Queueing

Integrated Services

- ❑ Datagram Service
- ❑ Controlled-Load Service: Performance as good as in an unloaded datagram network. No quantitative assurances.
- ❑ Guaranteed Service:
 - Firm bound on data throughput and delay.
 - Every element along the path must provide delay bound.
 - Is not always implementable, e.g., Ethernet.
 - Delay jitter or average delay not guaranteed or minimized.

Flow Specification

- ❑ Flow Spec = Traffic Spec + QoS Spec
= TSpec + RSpec
- ❑ TSpec: Peak rate (p), bucket rate (r), bucket size (b), max datagram size (M), min policed unit (m)
 - All datagrams less than m are counted as m bytes
 - Peak rate may be unknown or unspecified
- ❑ RSpec: Rate (R) and delay slack (S)
 S = Extra acceptable delay over that obtainable with R
Zero slack \Rightarrow Reserve exactly R .
- ❑ RSpec specified only for guaranteed rate service.
Not for controlled load service.

IS-Capable Router Components

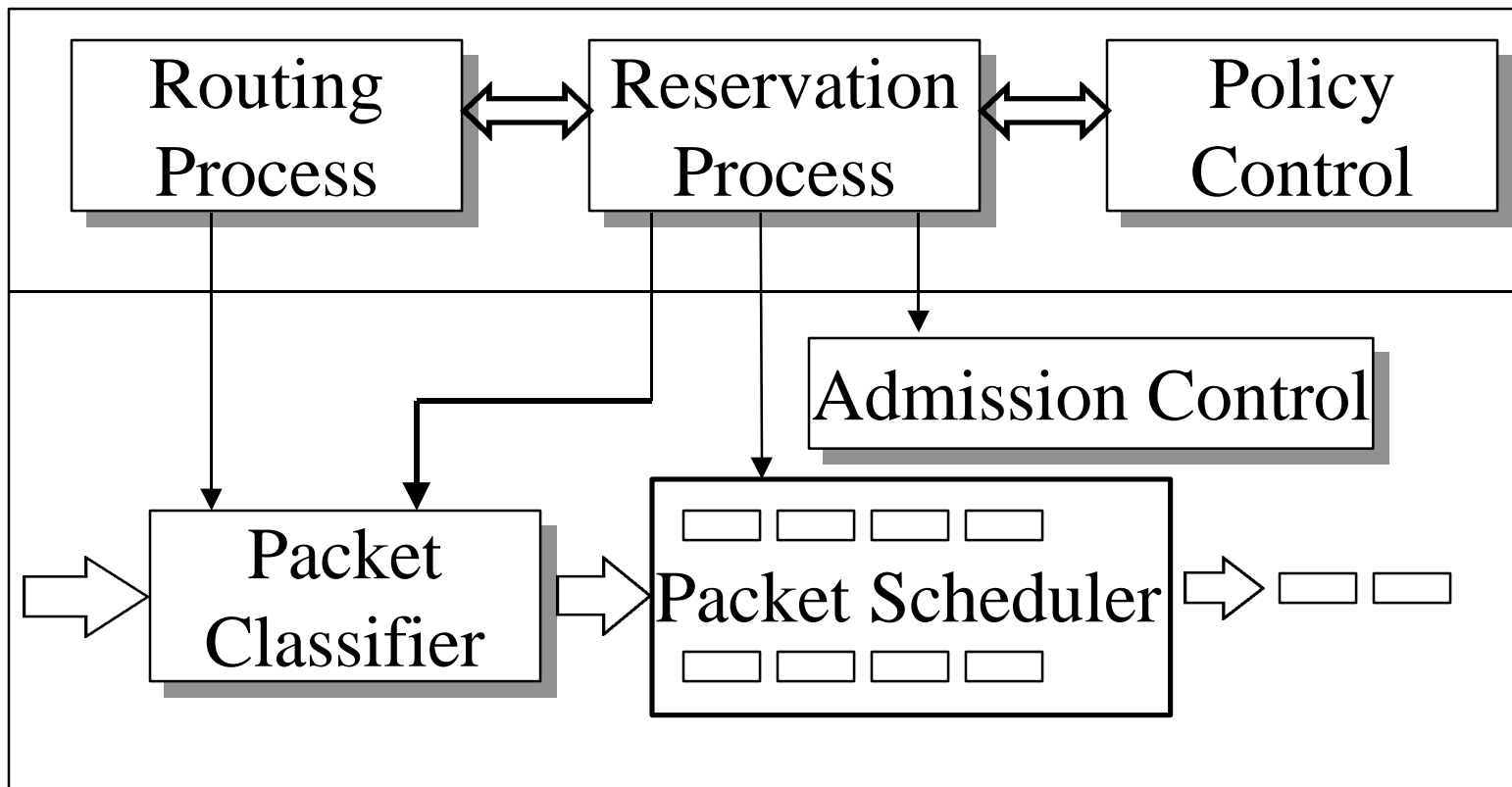

IS Router Components (Cont)

- ❑ Packet Scheduler:
Manages queues and timers for different streams
- ❑ Classifier:
Each incoming packet is examined to determine its class
Packets in the same flow may have “preemptable” (CLP) attribute
- ❑ Admission Control: Determine whether a new flow can be granted without affecting existing flows
- ❑ Reservation Setup Protocol: RSVP

RSVP

- ❑ Resource ReSerVation Protocol
- ❑ Internet signaling protocol
- ❑ Carries resource reservation requests through the network
- ❑ Receiver initiated reservations \Rightarrow Scales well
- ❑ Sets up reservations at each hop
- ❑ RSVP does not find routes.
Multicast routing protocols do.
- ❑ RSVP does not do: Routing, Admission control, Packet scheduling

Path Messages

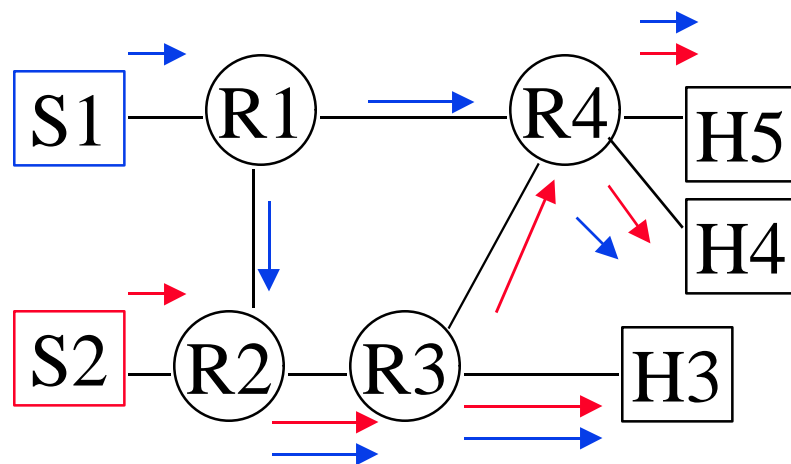

- ❑ Sources send quasi-periodic PATH messages to multicast address
- ❑ Path message contain “Flow spec”:
 - Sender Template: Data format, Src Address, Src Port
 - TSpec: Traffic Characteristics

Reservation (Cont)

- ❑ Requests are checked for resource availability (admission control) and administrative permissions (policy control)
- ❑ Two or more RESV messages for the same source over the same link are merged.
- ❑ Routers maintain a soft state.
The receivers have to refresh periodically.
- ❑ Heterogeneous Receivers: Sources divide traffic into several flows. Each flow is a separate RSVP flow. Receivers join one or more flows. Each RSVP flow is homogeneous.

Reservation (Cont)

- ❑ ResV messages contain Flow Spec + Filter Spec
- ❑ Filter Spec: Defines the packets in the flow
Used in packet classifier
- ❑ Flow Spec: Used in packet scheduler
Contents depends upon the service.
Will generally include TSpec and RSpec.

RSVP Reservation Styles

Source Selection	Reservation Usage	
	Separate	Shared
Wildcard	N/A	Wildcard Filter
Explicit	Fixed Filter	Shared-Explicit

- ❑ Fixed Filter: One pipe per source
- ❑ Wildcard Filter: One pipe for all sources on a session
- ❑ Shared-Explicit: Sources explicitly identified (Reserve for sources S3 or S4)

RSVP: Status

- ❑ Still an internet draft (May 1997)
Submitted to IESG area director.
- ❑ Multivendor interoperability demo at Sep'95 Interop.
- ❑ Product announced by Cisco.
- ❑ Unresolved Issues:
 - Accounting and charging
 - Authentication and access control
 - Session groups

RSVP vs UNI

Category	IP/RSVP	ATM UNI 3.0
Orientation	Receiver based	Sender based
State	Soft	Hard
QoS Setup time	Separate from route establishment	Concurrent with route establishment
Directionality	Unidirectional	Unidirectional multicast
Heterogeneity	Receiver heterogeneity	Uniform QoS to all receivers

- UNI 4.0 adds leaf initiated join.

RTP

- ❑ Real-Time Transport Protocol
- ❑ Not really an L4 protocol.
Common parts of several applications.
Uses UDP for multiplexing and checksum.
- ❑ Supports unicast and multicast delivery
- ❑ Source and payload type identification
- ❑ Sequencing, Timing, and Synchronization
- ❑ Source merging: Multiple contributing sources for a combined stream produced by an RTP mixer.
32-bit Synchronizing source (SSRC) id.
- ❑ Stream translation: High-speed to low speed

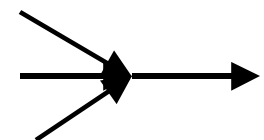

RTP (Cont)

- ❑ What RTP Does not Do?
 - Reliable data delivery
 - Quality of service guarantees
 - Resource reservations (RSVP)
 - Delivery of encryption key to participants
- ❑ RTP provides a general framework for applications to be able to do these ⇒ Application Level Framing
- ❑ Two components: RTP and Control (RTCP)
⇒ Simple RTP header
- ❑ Particular codings need additional parameters
⇒ RTP Profiles documents

RTCP

- ❑ Real-Time Transport Control Protocol
- ❑ Convey information about participants
- ❑ Convey information about relationships among sessions
- ❑ Monitor application performance
⇒ Feedback on quality of data
- ❑ Automatically adjusts overhead
(Report frequency based on participant count)

RTCP Packet Types

- ❑ Sender Report (SR):
Packets/bytes sent, lost
- ❑ Receiver Report (RR):
Packets/bytes received, lost, jitter
- ❑ Source Description (SDES)
- ❑ End of participation (BYE)
- ❑ Application Specific functions (APP)

RTSP

- ❑ Real time streaming protocol
- ❑ Application level protocol similar to hyper-text transfer protocol (HTTP/1.1) for audio/video
- ❑ Maintains state \Rightarrow Setup/teardown messages
- ❑ RTSP messages use TCP, UDP, ...
- ❑ Data transfer is done separately using TCP, RTP/UDP, ...
- ❑ Uses URLs, e.g.,
`rtsp://media.example.com:554/twister/audiotrack`
- ❑ Both servers and clients can issue requests.
HTTP servers do not issue requests.

RTSP Methods

- ❑ Setup: Start a new session
- ❑ Teardown
- ❑ Redirect
- ❑ Play
- ❑ Record
- ❑ Pause
- ❑ Describe: Tell me about session X
- ❑ Announce: A session X will take place at t
- ❑ Get_parameter: Get server/client statistics
- ❑ Set_parameter
- ❑ Options: I can accept only these options.

MBone

- ❑ Internet Multicast backbone
- ❑ Set of routers with IP multicasting
- ❑ IP multicast address: start with 1110... (binary), 224.0.0.0 to 239.255.255.255 (decimal)

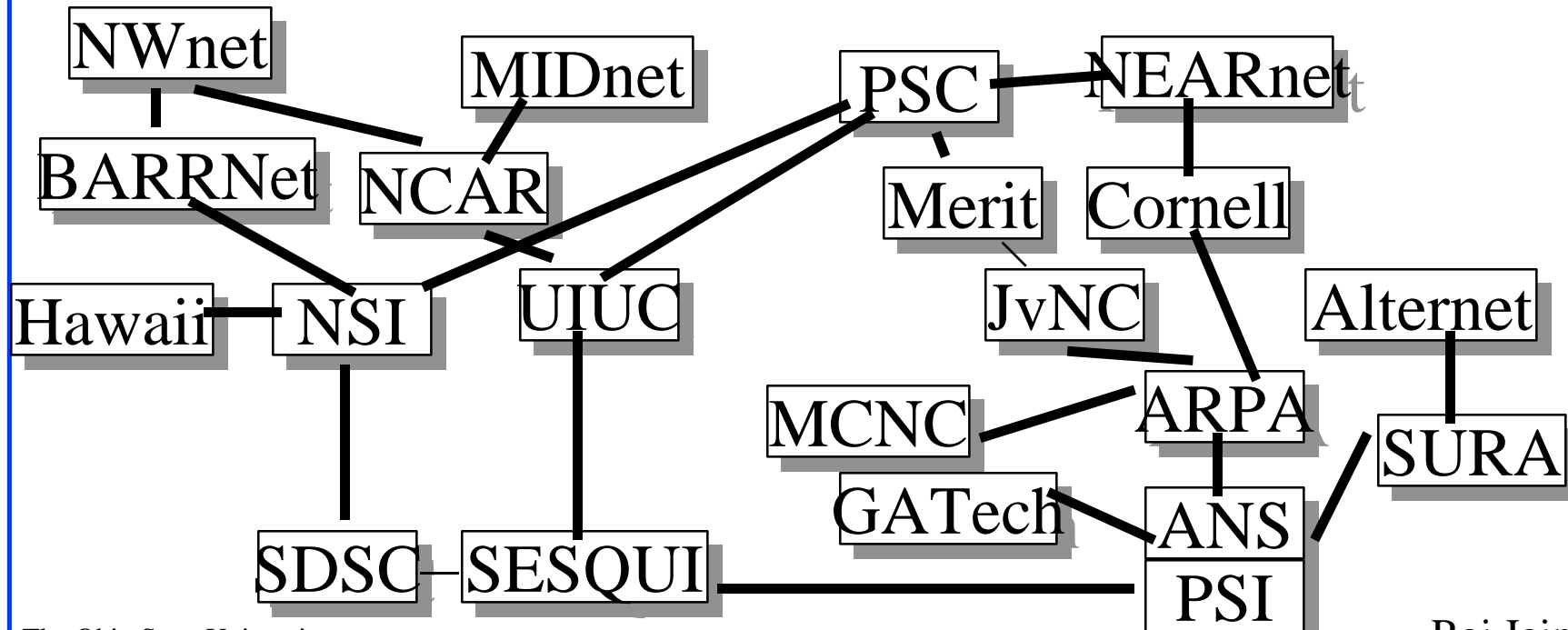

MBone (Cont)

- ❑ Uses radio/TV station paradigm: Sender is allocated a multicast address. It starts transmitting on that address
- ❑ Anyone can listen by tuning into the multicast address by sending an Internet Group Management Protocol (IGMP) request to router to join the multicast
- ❑ The router provides a connection to the nearest point
- ❑ First audiocast in March 1992: IETF meeting to 20 sites. Now over 600 hosts in over 15 countries
- ❑ Multicast routers setup tunnels between them.
Tunnel = direct connection

Tunnels

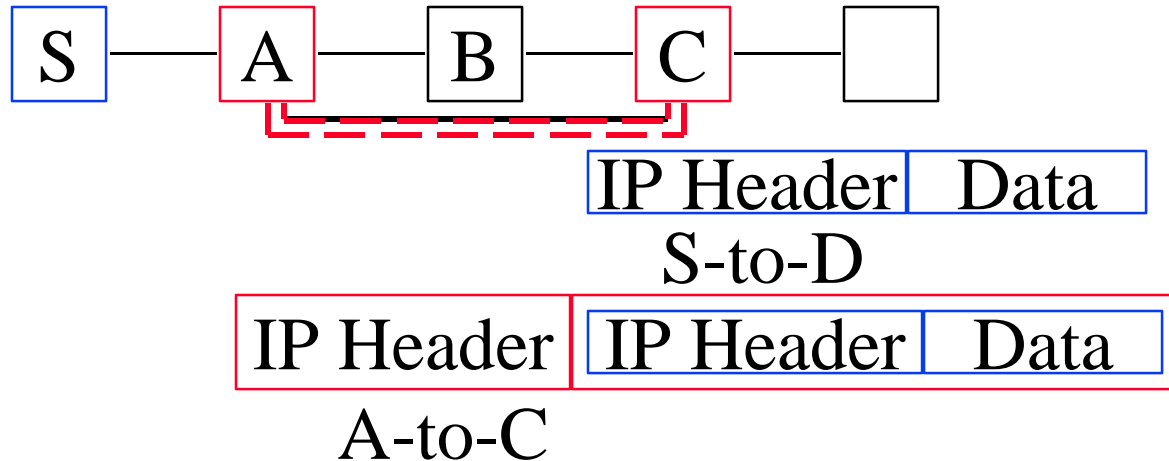

- ❑ Implemented by encapsulating the entire packet in another IP header.
- ❑ Each tunnel has a cost. Least cost path is found by exchanging distance-vectors with neighbors.

Internet Bandwidth Scarcity

- ❑ Each tunnel requires 100 to 300 kbps.
Use 500 kbps for design.
A few tunnels can saturate the host.
Four on SPARC 1, six on SPARC 10.
Maximum two tunnels over T1.
- ❑ Each packet has a time to live (TTL).
TTL is decremented at each router.
The packet is forwarded iff its TTL is over a threshold.
- ❑ Pruning: If a multicast router gets a packet for which it has no listeners, it sends a message to the upstream multicast router to stop sending.

SDP

- ❑ Session Description Protocol
- ❑ Used by session directory tool on MBone to announce sessions
- ❑ Currently SDP V2
- ❑ Example:
 - s = Netlab Seminars
 - i = Seminars on recent advances in networking
 - o = maf@net.osu.edu
 - c = 224.5.17.11 127 2873397496 2873404696
 - m = audio 3456 0
 - m = video 2232 0

ST2+

- ❑ Stream protocol
- ❑ Connection oriented IP. IPv5
- ❑ Uses IP addressing, routing tables
- ❑ Source oriented: Sources setup real-time stream using a flow specification.
- ❑ Stream Message Control Protocol (SCMP)|
Like ICMP. Used to setup/teardown flows.
Connect, Accept, Disconnect, Refuse, Change, Join
- ❑ Single rate for all destinations.
- ❑ Implementations in DEC, NeXT, Mac, PC, SGI, Sun

Summary

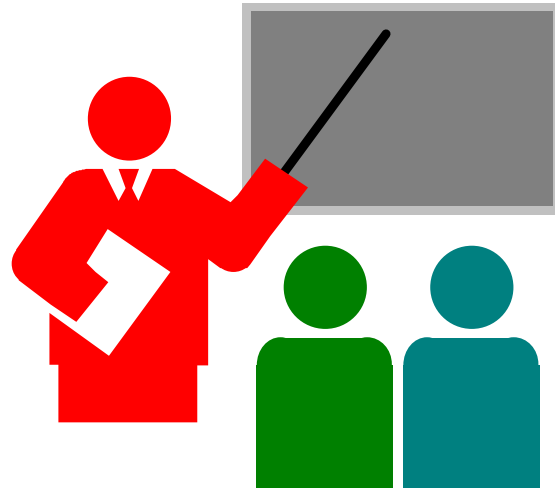

- ❑ TCP/IP protocols suite is being extended to allow multimedia on Internet
- ❑ Signaling protocol: RSVP
- ❑ Transport Protocol: RTP, RTCP, RTSP
- ❑ IP Multicast backbone (MBone), SDP
- ❑ Connection-oriented IP (ST2+)

References

- ❑ For a detailed list of references see:
http://www.cis.ohio-state.edu/~jain/refs/mul_refs.htm
- ❑ "Specification of Guaranteed Quality of Service", 7/7/1997, <http://www.internic.net/internet-drafts/draft-ietf-intserv-guaranteed-svc-08.txt>
- ❑ "Specification of the Controlled-Load Network Element Service", 5/29/1997, <http://www.internic.net/internet-drafts/draft-ietf-intserv-ctrl-load-svc-05.txt>

References (Cont)

- ❑ "Resource ReSerVation Protocol (RSVP) -- Version 1 Functional Specification", 6/16/1997, <http://www.internic.net/internet-drafts/draft-ietf-rsvp-spec-16.txt>
- ❑ RFC 1889, RTP: A Transport Protocol for Real-Time Applications
- ❑ "Real Time Streaming Protocol (RTSP)", 08/02/1997, <http://www.internic.net/internet-drafts/draft-ietf-mmusic-rtsp-03.txt>

References (Cont)

- ❑ The MBONE information web,
<http://www.mbone.com/>
- ❑ RFC 1819, Internet Stream Protocol Version 2 (ST2) Protocol Specification - Version ST2+
- ❑ SDP: Session Description Protocol,
3/26/97, [http://www.internic.net/
internet-drafts/draft-ietf-mmusic-sdp-03.txt](http://www.internic.net/internet-drafts/draft-ietf-mmusic-sdp-03.txt)

IETF Multimedia Working Groups

- ❑ Audio/Video Transport (avt)
- ❑ Integrated Services (intserv)
- ❑ Integrated Services over Specific Link Layers (issll)
- ❑ Resource Reservation Setup Protocol (rsvp)
- ❑ MBONE deployment working group (mboned)
- ❑ Multiparty Multimedia Session Control (mmusic)
- ❑ Multicast Extensions to OSPF (mospf)
- ❑ Inter-Domain Multicast Routing (idmr)