

ATM Traffic Management and LAN Emulation

Raj Jain

Professor of Computer and Information Sciences

The Ohio State University

<http://www.cis.ohio-state.edu/~jain/cis788-97/>



- ❑ ATM Classes of Service
- ❑ ATM Traffic Management
- ❑ Available Bit Rate (ABR)
- ❑ LAN Emulation (LANE)
- ❑ LANE V2.0.

Dime Sale

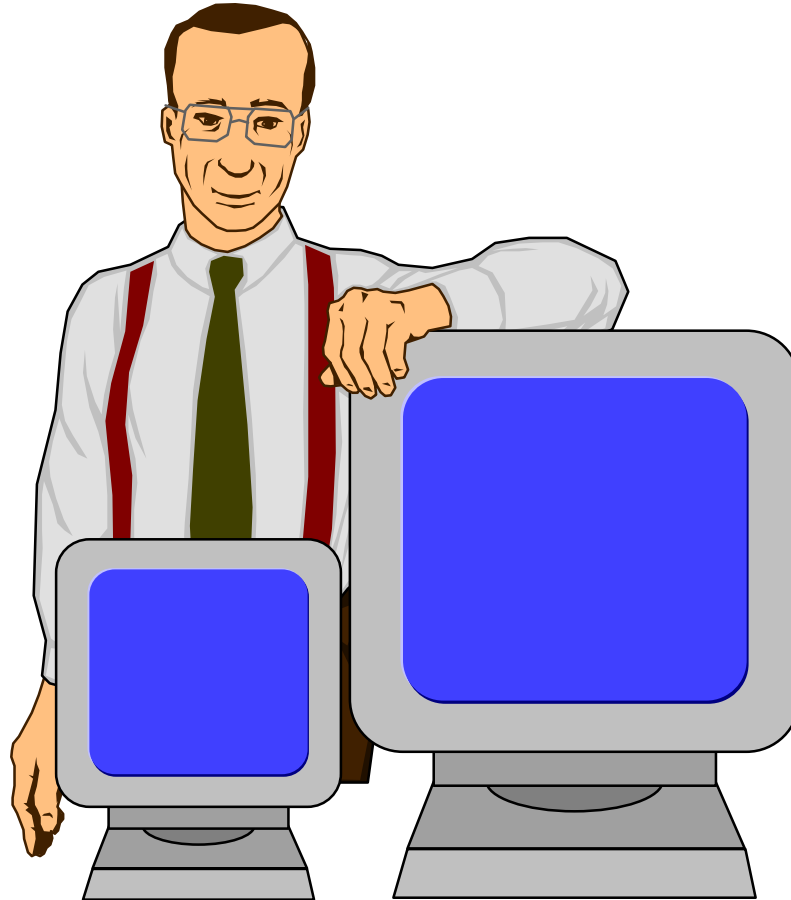

One Megabit memory, One Megabyte disk, One Mbps link, One MIP processor, 10 cents each.....

Future

Year

1980



In 1990, the memory will be so cheap that you will not have to worry about paging, swapping, virtual memory, memory hierarchy, and....

Traffic Management on the Info Superhighway

① CAC



② Shaping

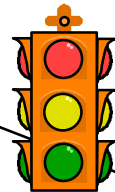

③ UPC

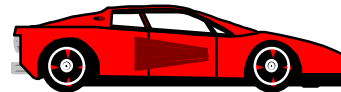
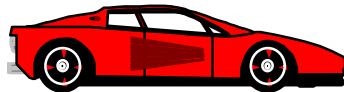
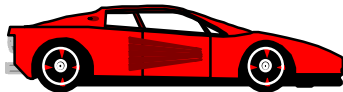

Scheduling ④

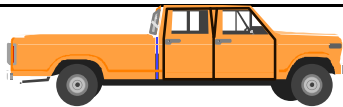

⑤ Selective

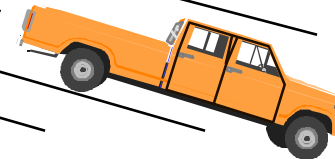
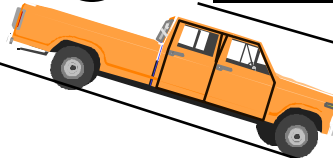

⑥

Frame Discard

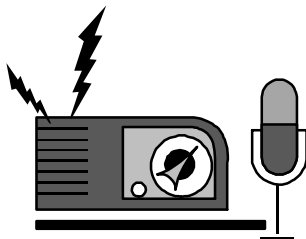

⑦

Traffic Monitoring and feedback

Traffic Mgmt Functions

- ❑ Connection Admission Control (CAC):
Can quality of service be supported?
- ❑ Traffic Shaping: Limit burst length. Space-out cells.
- ❑ Usage Parameter Control (UPC):
Monitor and control traffic at the network entrance.
- ❑ Network Resource Management:
Scheduling, Queueing, resource reservation
- ❑ Priority Control: Cell Loss Priority (CLP)
- ❑ Selective Cell Discarding: Frame Discard
- ❑ Feedback Controls: Network tells the source to increase or decrease its load.

Classes of Service

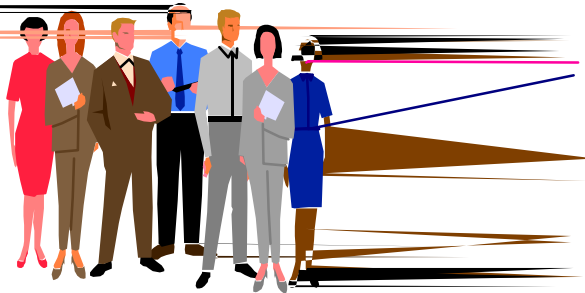

Standby



Guaranteed



Joy Riders



Confirmed



Raj Jain

Classes of Service

- ❑ **ABR** (Available bit rate):
Source follows network feedback.
Max throughput with minimum loss.
- ❑ **UBR** (Unspecified bit rate):
User sends whenever it wants. No feedback. No guarantee. Cells may be dropped during congestion.
- ❑ **CBR** (Constant bit rate): User declares required rate.
Throughput, delay and delay variation guaranteed.
- ❑ **VBR** (Variable bit rate): Declare avg and max rate.
 - **rt-VBR** (Real-time): Conferencing.
Max delay guaranteed.
 - **nrt-VBR** (non-real time): Stored video.

ABR: Binary Rate-based Scheme

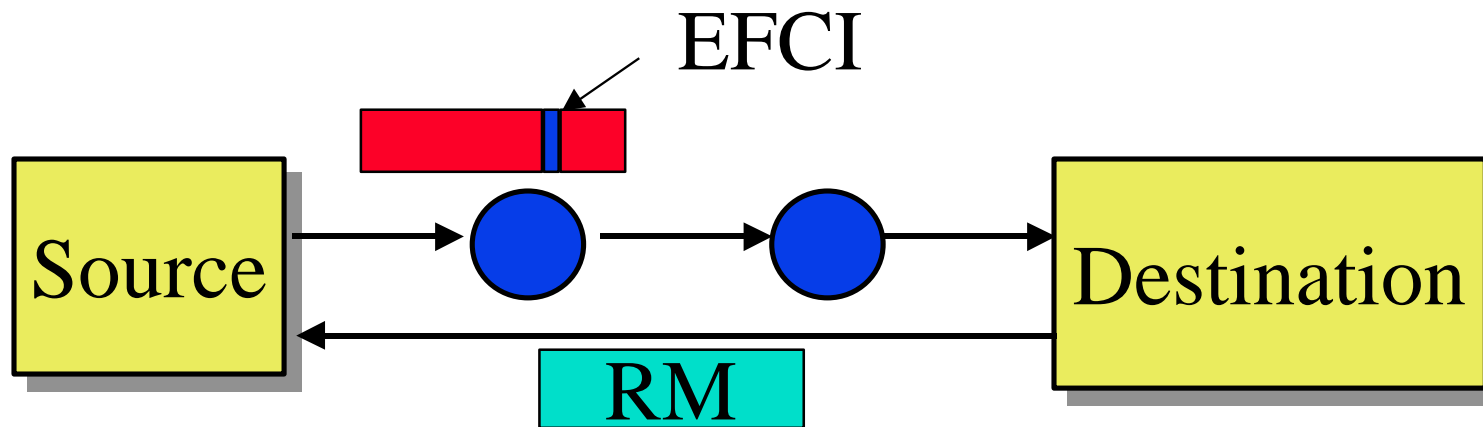

- ❑ Explicit forward congestion indicator (EFCI) set to 0 at source
- ❑ Congested switches set EFCI to 1
- ❑ Every n th cell, destination sends an resource management (RM) cell to the source indicating increase amount or decrease factor

The Explicit Rate Scheme

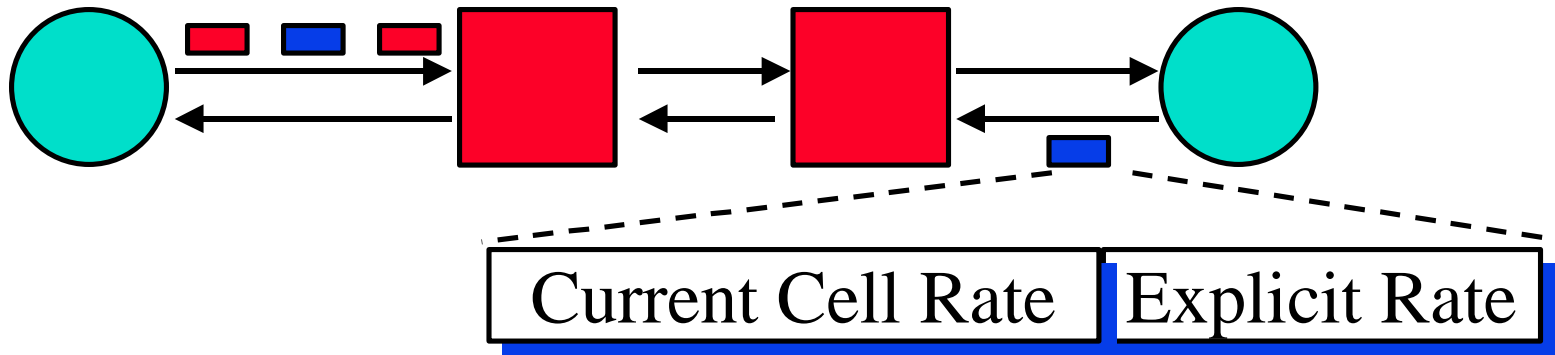

- ❑ Sources send one **RM cell** every n cells
- ❑ The RM cells contain “**Explicit rate**”
- ❑ Destination returns the RM cell to the source
- ❑ The switches adjust the rate **down**
- ❑ Source adjusts to the specified rate

LAN Emulation

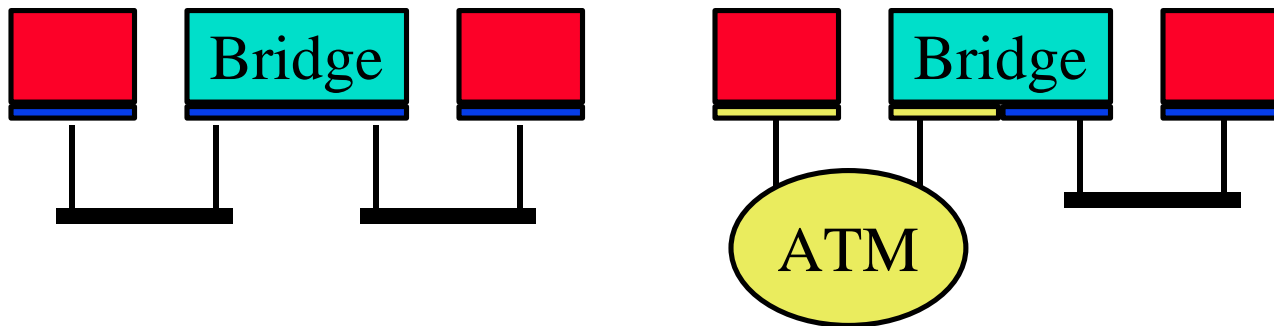

- ❑ Problem: Need new networking s/w for ATM
- ❑ Solution: Let ATM network appear as a virtual LAN
- ❑ LAN emulation implemented as a device driver below the network layer

Features

- ❑ One ATM LAN can be n virtual LANs
- ❑ Logical subnets interconnected via routers
- ❑ Need drivers in hosts to support each LAN
- ❑ Only **IEEE 802.3** and **IEEE 802.5** frame formats supported. (FDDI can be easily done.)
- ❑ Doesn't allow passive monitoring
- ❑ No token management (SMT), collisions, beacon frames.
- ❑ Allows larger frames.

LE Header (2 Bytes)

IEEE 802.3 or 802.5 Frame

Protocol Layers

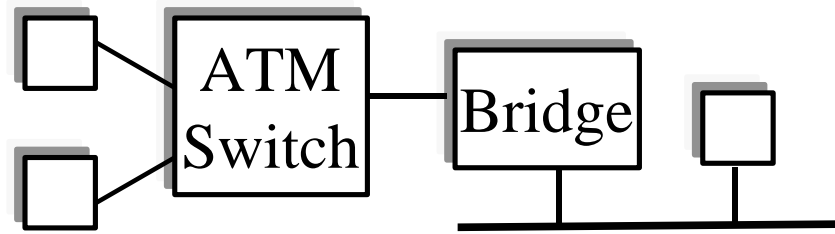

ATM Host	
Applications	
IP	IPX
NDIS	ODI
LAN Emulation	
AAL5	
ATM	
Physical Layer	

ATM Switch	
ATM	
Phy Layer	Phy Layer

ATM-LAN Bridge	
Bridging	
LAN Emulation	Media Access Control
AAL5	
ATM	
Phy Layer	Phy Layer

LAN Host	
Applications	
IP	IPX
NDIS	ODI
Media Access Control	
Physical Layer	

Protocol Layers (Cont)

- ❑ NDIS = Network Driver Interface Specification
- ❑ ODI = Open Datalink Interface
- ❑ IPX = NetWare Internetworking Protocol
- ❑ **LAN Emulation Software:**
 - ❑ LAN Emulation Clients in each host
 - ❑ LAN Emulation Servers
 - ❑ LAN Emulation Configuration server (LECS)
 - ❑ LAN Emulation Server (LES)
 - ❑ Broadcast and unknown server (BUS)

LAN Emulation

1. Client gets recipient's address from LES and sets-up a VC.

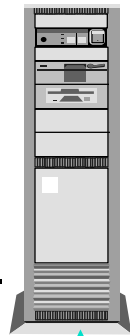

LAN Emulation Server

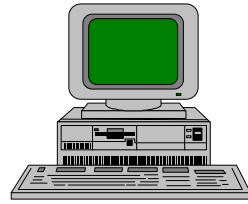

3. Messages for ATM clients are delivered directly.

Switches

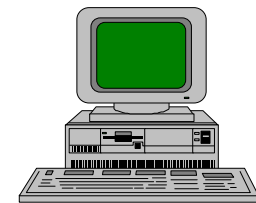
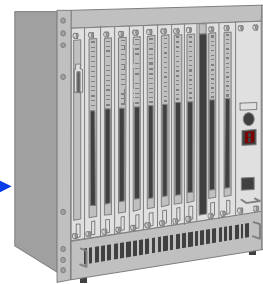
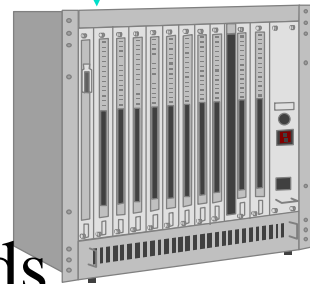
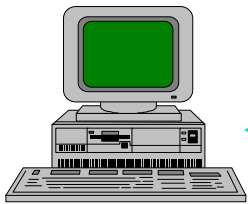

ATM client B
Bridge

2. Client sends messages on the VC

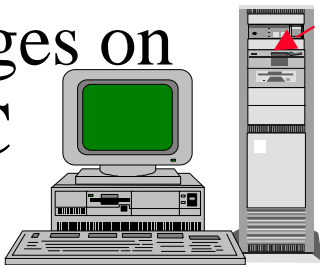

4. Messages for non-ATM clients are forwarded through bridges

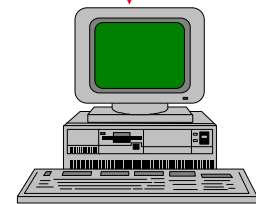

Broadcast/Unknown Server (BUS)

Non-ATM client

Raj Jain

Operation

□ Initialization:

- Client gets address of LAN Emulation Configuration Server (LECS) from its switch, uses well-known LECS address, or well known LECS PVC
- Client gets Server's address from LECS

□ Registration:

- Client sends a list of its MAC addresses to Server.
- Declares whether it wants ARP requests.

Operation (Cont)

- Address Resolution:
 - Client sends ARP request to Server.
 - Unresolved requests sent to clients, bridges.
 - Server, Clients, Bridges answer ARP
 - Client setups a direct connection
- Broadcast/Unknown Server (BUS):
 - Forwards multicast traffic to all members
 - Clients can also send unicast frames for unknown addresses

Flush Protocol

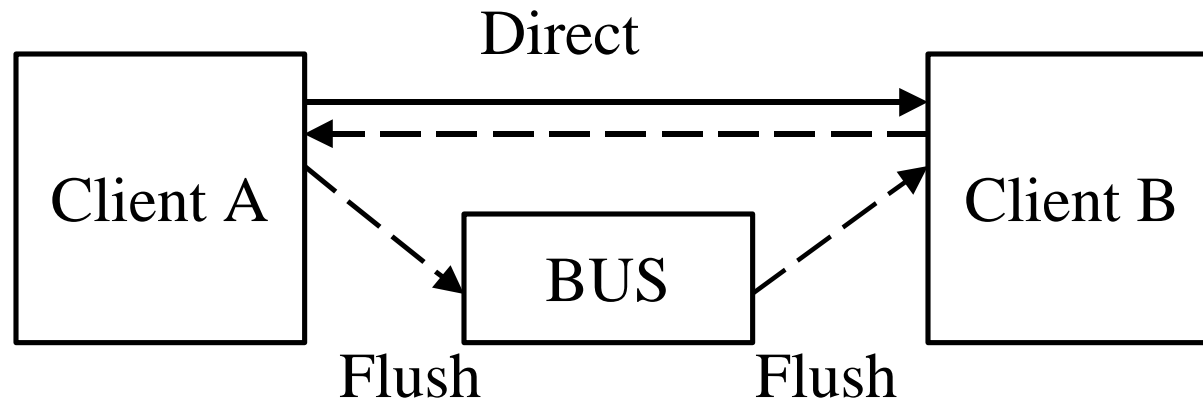

- ❑ Clients can send unicast packets via BUS while trying to resolve the address \Rightarrow Out-of-order arrivals
- ❑ When the direct VCC is setup, clients send a “Flush message” to destination. Destination returns it to source. Source can then send packets on direct VC.

LANE v2.0

- Allows multiple LE Servers:
LES, BUS, and LECS on a single ELAN
- LAN Emulation network-to-network interface (LNNI): Specifies interfaces for communication between the LE server entities.

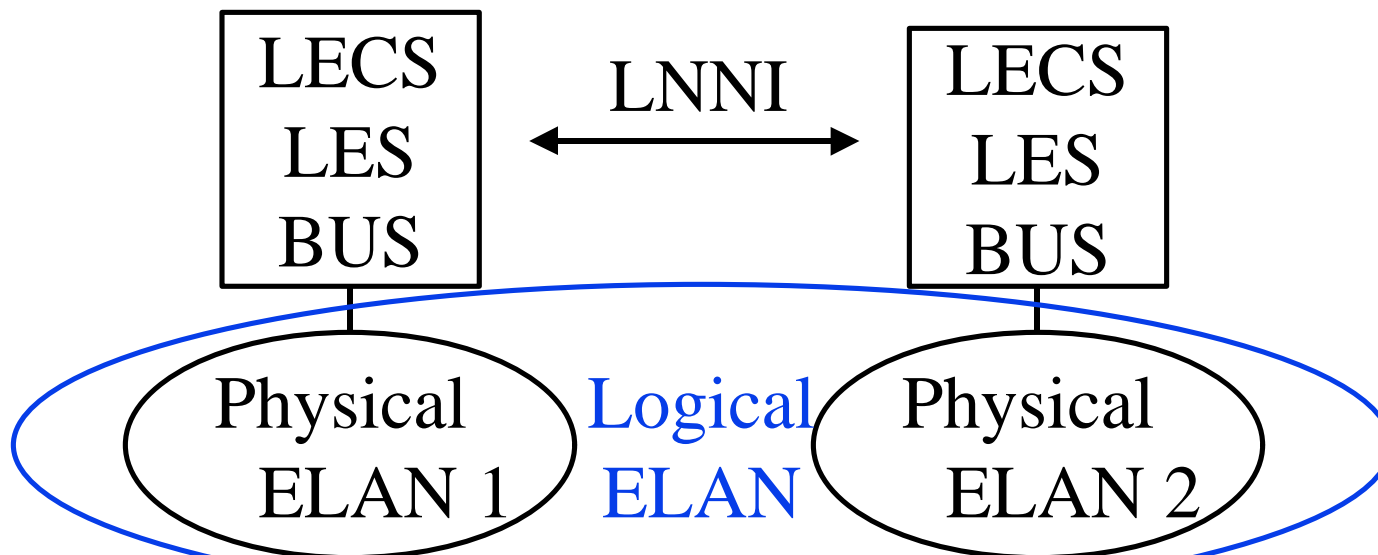

LANE v2.0 (Cont)

- ❑ Server cache synchronization protocol
- ❑ Changes to LAN Emulation

User-to-network Interface (LUNI):

- Quality of service (8 global classes)
- Enhanced support for PVC
- LLC multiplexing
- Support for ABR
- Enhanced multicast support

Multicast trees (VCs) different from broadcast tree

- ❑ Status: LUNI 2.0 was in straw ballot in April 97

ATM Virtual LANs

Physical View

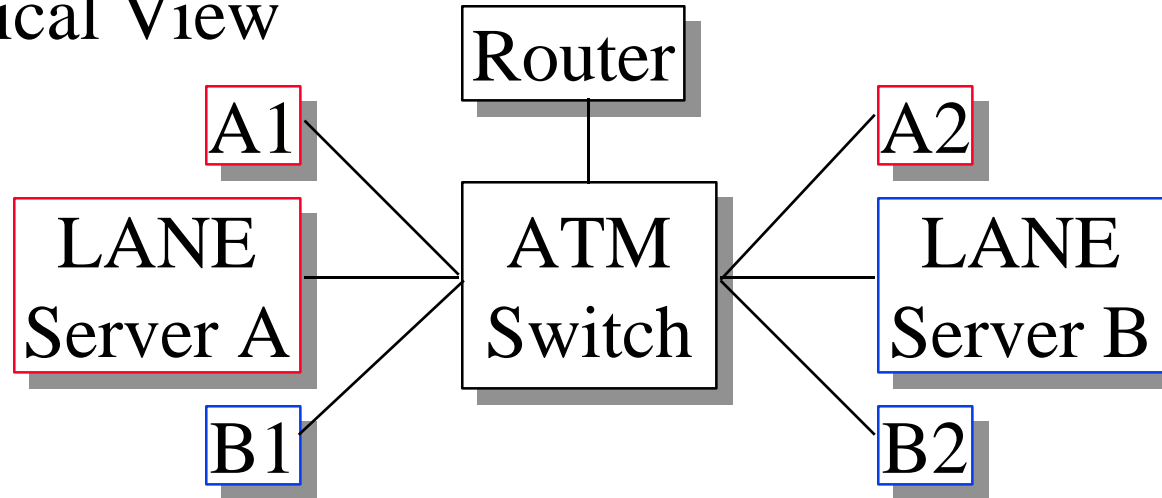

Logical View

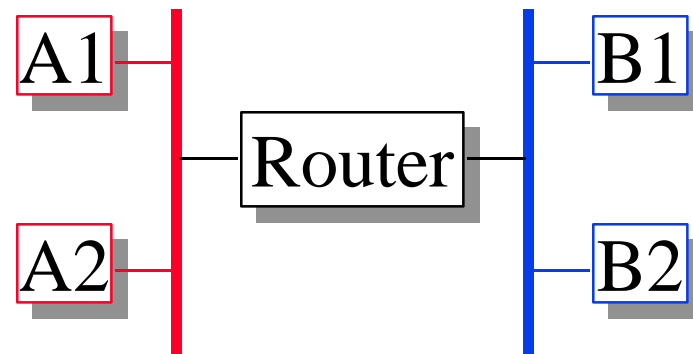

Summary

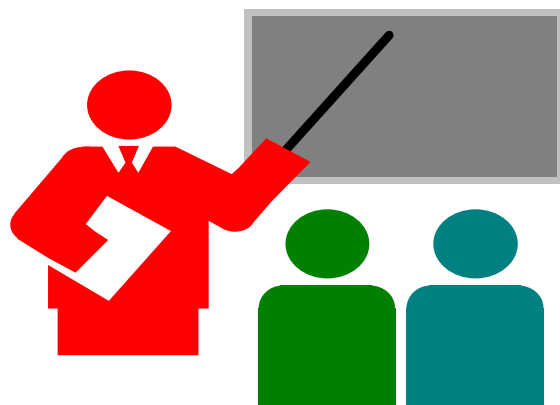

- ❑ ATM has sophisticated traffic management
- ❑ CBR, ABR, UBR
- ❑ ABR provides feedback
- ❑ LANE allows current applications to run on ATM
- ❑ LANE V2 allows multiple servers \Rightarrow Bigger ELANs

Homework

- Read Section 14.3 of Stallings