

.....
ATM Forum Document Number: ATM_Forum/97-0426.
.....

Title: Proposed modifications to Performance Testing Baseline: Throughput and Latency Metrics
.....

Abstract: This revised text of the baseline includes better descriptions of test configurations and measurement procedures for throughput and latency sections of the baseline documents. New text for Appendix A on MIMO latency is also included.
.....

Source:
Gojko Babic, Arjan Durresi, Raj Jain, Justin Dolske, Shabbir Shahpurwala
The Ohio State University
Department of CIS Columbus, OH 43210-1277
Phone: 614-292-3989, Fax: 614-292-2911, Email: Jain@ACM.Org

The presentation of this contribution at the ATM Forum is sponsored by NASA.
.....

Date: April 1997
.....

Distribution: ATM Forum Technical Working Group Members (AF-TEST, AF-TM)
.....

Notice:
This contribution has been prepared to assist the ATM Forum. It is offered to the Forum as a basis for discussion and is not a binding proposal on the part of any of the contributing organizations. The statements are subject to change in form and content after further study. Specifically, the contributors reserve the right to add to, amend or modify the statements contained herein.
.....

3.1. Throughput

3.1.1. Definitions

There are three frame-level throughput metrics that are of interest to a user:

- **Lossless throughput** - It is the maximum rate at which none of the offered frames is dropped by the SUT.
- **Peak throughput** - It is the maximum rate at which the SUT operates regardless of frames dropped. The maximum rate can actually occur when the loss is not zero.
- **Full-load throughput** - It is the rate at which the SUT operates when the input links are loaded at 100% of their capacity.

A model graph of throughput vs. input rate is shown in Figure 3.1. Level X defines the lossless throughput, level Y defines the peak throughput and level Z defines the full-load throughput.

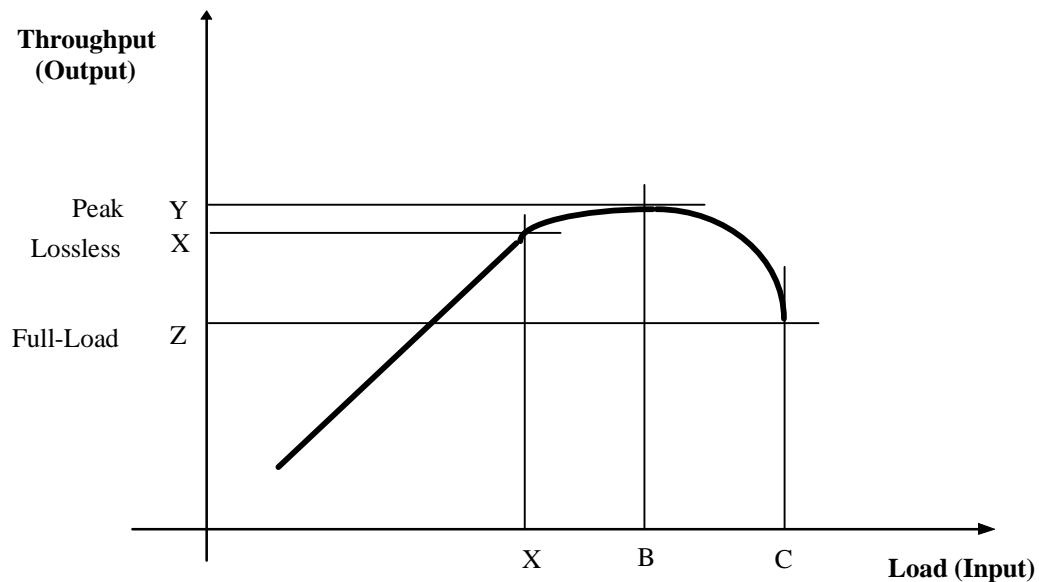

Figure 3.1: Peak, lossless and full-load throughput

The lossless throughput is the highest load at which the count of the output frames equals the count of the input frames. The peak throughput is the maximum throughput that can be achieved in spite of the losses. The full-load throughput is the throughput of the system at 100% load on input links. Note that the peak throughput may equal the lossless throughput in some cases.

Only frames that are received completely without errors are included in frame-level throughput computation. Partial frames and frames with CRC errors are not included.

3.1.2. Units

Throughput should be expressed in the effective bits/sec, counting only bits from frames excluding the overhead introduced by the ATM technology and transmission systems.

This is preferred over specifying it in frames/sec or cells/sec. Frames/sec requires specifying the frame size. The throughput values in frames/sec at various frame sizes cannot be compared without first being converted into bits/sec. Cells/sec is not a good unit for frame-level performance since the cells aren't seen by the user.

3.1.3. Statistical Variations

There is no need for obtaining more than one sample for any of the three frame-level throughput metrics. Consequently, there is no need for calculation of the means and/or standard deviations of throughputs.

3.1.4. Measurement Procedures

Before starting measurements, a number of VCCs (or VPCs), henceforth referred to as "foreground VCCs", are established through the SUT. Foreground VCCs are used to transfer only the traffic whose performance is measured. That traffic is referred as the foreground traffic. Characteristics of a foreground traffic are specified in 3.1.5.

The tests can be conducted under two conditions:

- without background traffic;
- with background traffic;

Procedure without background traffic

The procedure to measure throughput in this case includes a number of test runs. A test run starts with the traffic being sent at a given input rate over the foreground VCCs with early packet discard disabled (if this feature is available in the SUT and can be turned off). The average cell transfer delay is constantly monitored. A test run ends and the foreground traffic is stopped when the average cell transfer delay has not significantly changed (not more than 5%) during a period of at least 5 minutes.

During the test run period, the total number of frames sent to the SUT and the total number of frames received from the SUT are recorded. The throughput (output rate) is computed based on the duration of a test run and the number of received frames.

If the input frame count and the output frame count are the same then the input rate is increased and the test is conducted again.

The lossless throughput is the highest throughput at which the count of the output frames equals the count of the input frames.

The input rate is then increased even further (with early packet discard enabled, if available). Although some frames will be lost, the throughput may increase till it reaches the peak throughput value. After this point, any further increase in the input rate will result in a decrease in the throughput.

The input rate is finally increased to 100% of the link input rates and the full-load throughput is recorded.

Procedure with background traffic

Measurements of throughput with background traffic are under study.

3.1.5. Foreground Traffic

Foreground traffic is specified by the type of foreground VCCs, connection configuration, service class, arrival patterns, frame length and input rate.

Foreground VCCs can be permanent or switched, virtual path or virtual channel connections, established between ports on the same network module on the switch, or between ports on different network modules, or between ports on different switching fabrics.

A system with n ports can be tested for the following connection configurations:

- n -to- n straight,
- n -to- $(n-1)$ full cross,
- n -to- m partial cross, $1 \leq m \leq n-1$,
- k -to-1, $1 < k < n$,
- 1-to- $(n-1)$.

Different connection configurations are illustrated in Figure 3.2, where each configuration includes one ATM switch with four ports, with their input components shown on the left and their output components shown the right.

In the case of n -to- n straight, input from one port exits to another port. This represents almost no path interference among the foreground VCCs. There are n foreground VCCs. See Figure 3.2a.

In the case of n -to- $(n-1)$ full cross, input from each port is divided equally to exit on each of the other $(n-1)$ ports. This represents intense competition for the switching fabric by the foreground VCCs. There are $n \times (n-1)$ foreground VCCs. See Figure 3.2b.

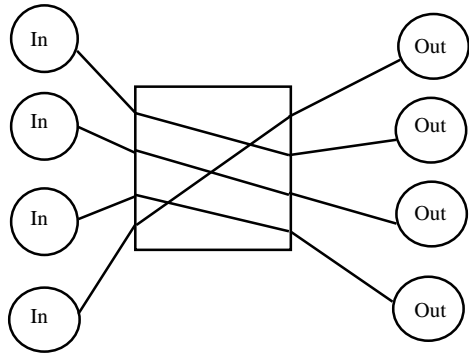
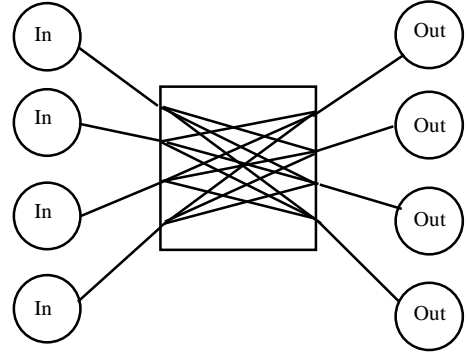
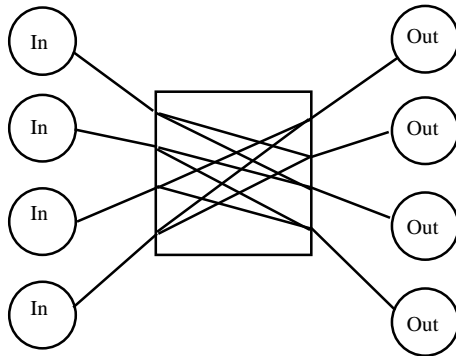
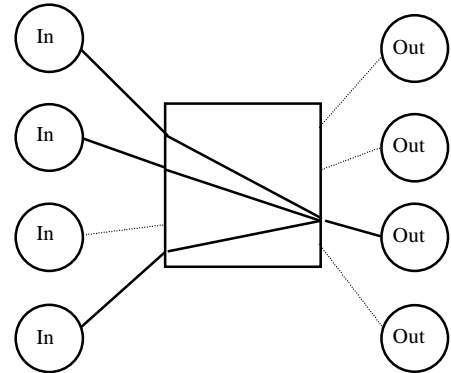
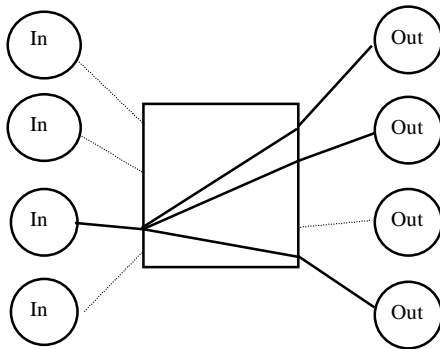
a. n-to-n straight: n VCCs; $n=4$ b. n-to-(n-1) full cross: $n \times (n-1)$ VCCs; $n=4$ c. n-to-m partial cross: $n \times m$ VCCs; $n=4$, $m=2$ d. k-to-1: k VCCs; $k=3$ 

e. 1-to-(n-1): one (multicast) VCC

Figure 3.2: Connection configurations for foreground traffic

In the case of n-to-m partial cross, input from each port is divided equally to exit on the other m ports ($1 \leq m \leq n-1$). This represents partial competition for the switching fabrics by the foreground VCCs. There are $n \times m$ foreground VCCs as shown in Figure 3.2c. Note that n-to-n straight and n-to-(n-1) full cross are special cases of n-to-m partial cross with $m=1$ and $m=n-1$, respectively.

In the case of k -to-1, input from k ($1 < k < n$) ports is destined to one output port. This stresses the output port logic. There are k foreground VCCs as shown in Figure 3.2d.

In the case of 1-to- $(n-1)$, all foreground frames input on the one designated port are multicast to all other $(n-1)$ ports. This tests the multicast performance of the switch. There is only one (multicast) foreground VCC as shown in Figure 3.2e.

Use of the 1-to- $(n-1)$ connection configuration for the foreground traffic is under study.

The following service classes, arrival patterns and frame lengths for foreground traffic are used for testing:

- UBR service class: Traffic consists of equally spaced frames of fixed length. Measurements are performed at AAL payload size of 64 B, 1518 B, 9188 B and 64 kB. Variable length frames and other arrival patterns (e.g. self-similar) are under study.
- ABR service class is under study.

The required input rate of foreground traffic is obtained by loading each link by the same fraction of its input rate. In this way, the input rate of foreground traffic can also be referred to as a fraction (percentage) of input link rates. The maximum foreground load (MFL) is defined as the sum of rates of all links in the maximum possible switch configuration. Input rate of the foreground traffic is expressed in the effective bits/sec, counting only bits from frames, excluding the overhead introduced by the ATM technology and transmission systems.

3.1.6. Background Traffic

Higher priority traffic (like VBR or CBR) can act as background traffic for experiments. Further details of measurements with background traffic using multiple service classes simultaneously are under study. Until then, all testing will be done without any background traffic.

3.1.7. Guidelines For Scaleable Test Configurations

It is obvious that testing larger systems, e.g., switches with larger number of ports, could require very extensive (and expensive) measurement equipment. Hence, we introduce scaleable test configurations for throughput measurements that require only one ATM monitor with one generator/analyzer pair. Figure 3.3 presents a simple test configuration for an ATM switch with eight ports in a 8-to-8 straight connection configuration. Figure 3.4 presents a test configuration with the same switch in an 8-to-2 partial cross connection configuration. The former configuration emulates 8 foreground VCCs, while the later emulates 16 foreground VCCs.

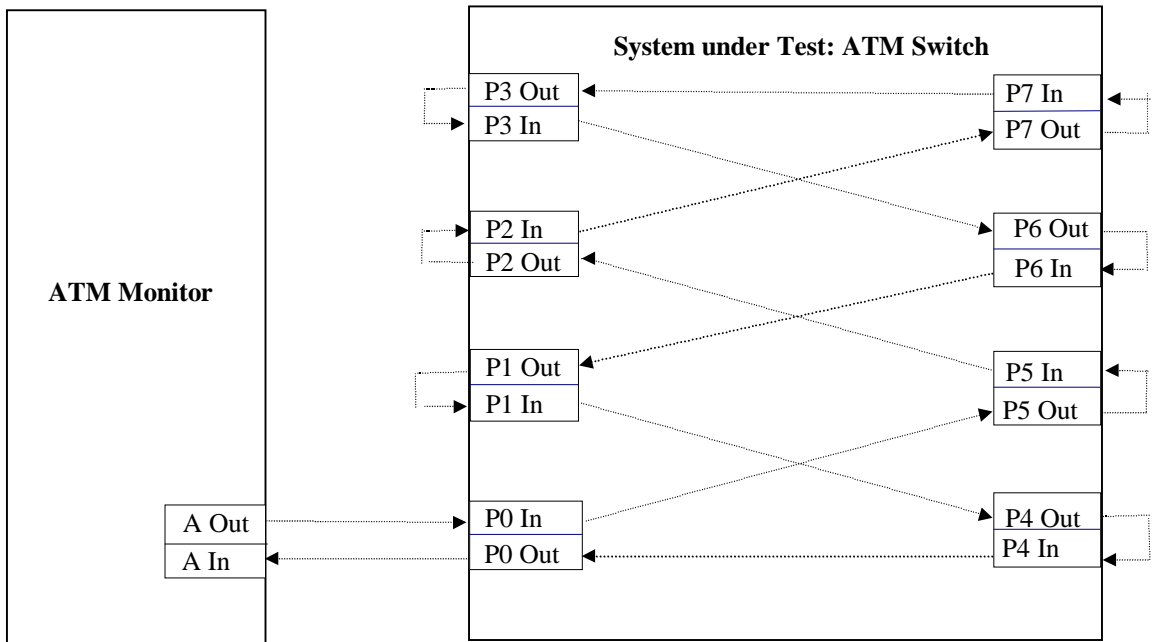

Figure 3.3: A scaleable test configuration for throughput measurements using only one generator/analyzer pair with 8-port switch and a 8-to-8 straight connection configuration

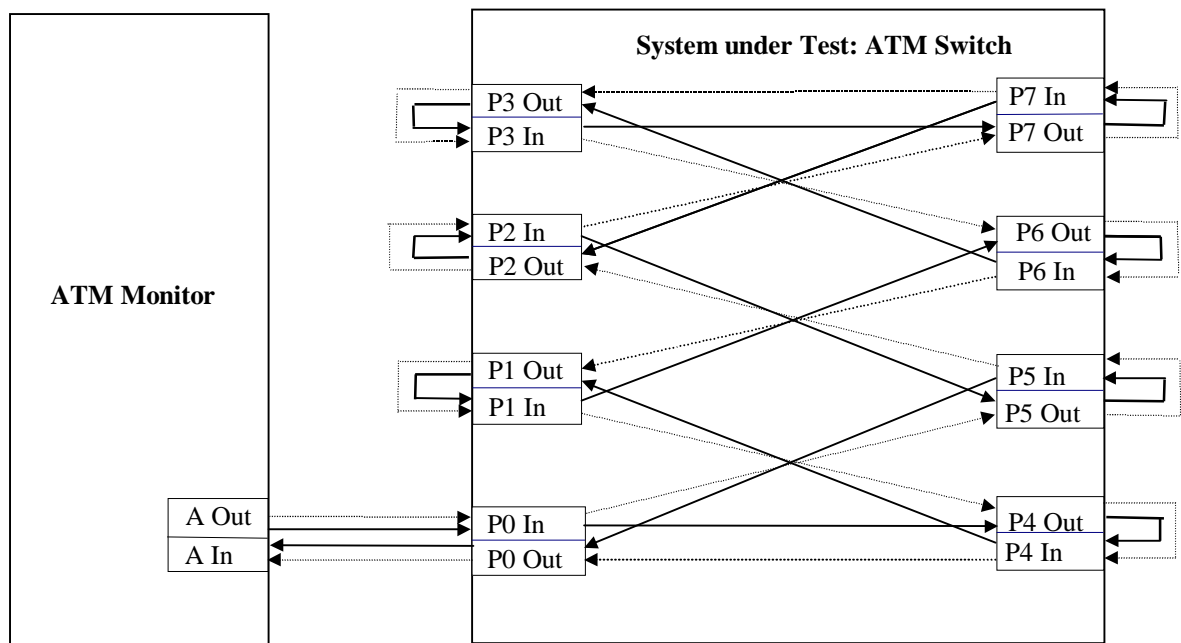

Figure 3.4: A scaleable test configuration for throughput measurements using only one generator/analyzer pair with 8-port switch and a 8-to-2 partial cross connection configuration

In both test configurations, there is one link between the ATM monitor and the switch. The other seven ports have external loopbacks. A loopback on a given port causes the frames transmitted over the output of the port to be received by the input of the same port.

The test configurations in Figure 3.3 and Figure 3.4 assume two network modules in the switch, with switch ports P0-P3 in one network module and switch ports P4-P7 in the another network module. Foreground VCCs are always established from a port in one network module to a port in the another network module. These connection configurations could be more demanding on the SUT than the cases where each VCC uses ports in the same network module. An even more demanding case could be when foreground VCCs use different fabrics of a multi-fabric switch.

Approaches similar to those in Figure 3.3 and Figure 3.4 can be used for n-to-(n-1) full cross and other types of n-to-m partial cross connection configurations, as well as for larger switches. Guidelines to set up scaleable test configurations for the k-to-1 connection configuration are under study.

It should be noted that in the proposed test configurations, because of loopbacks, only permanent VCCs or VPCs can be established

It should also be realized that in the test configurations with loopbacks, if all link rates are not identical, it is not possible to generate foreground traffic equal to the MFL. The maximum foreground traffic load for a n-port switch in those cases equals $n \times$ lowest link rate. Only in the case when all link rates are identical is it possible to obtain MFL level. If all link rates are not identical, and the MFL level needs to be reached, it is necessary to have more than one analyzer/generator pair.

3.1.8. Reporting results

Results should include a detailed description of the SUT, such as the number of ports, rate of each port, number of ports per network module, number of network modules, number of network modules per fabric, number of fabrics, maximum foreground load (MFL), software version, and any other relevant information.

Values for the lossless throughput, the peak throughput with corresponding input load, and the full-load throughput with corresponding input load (if different from MFL) are reported along with foreground (and background, if any) traffic characteristics.

The list of foreground traffic characteristics and their possible values are now provided:

- type of foreground VCCs: permanent virtual path connections, switched virtual path connections, **permanent virtual channel connections**, switch virtual channel connections;

- foreground VCCs established: between ports inside a network module, **between ports on different network modules**, between ports on different fabrics, some combination of previous cases;
- connection configuration: n-to-n straight, n-to-(n-1) full cross, **n-to-m partial cross** with $m = 2, 3, 4, \dots, n-1$, **k-to-1** with $k=2, 3, 4, 5, 6, \dots$;
- service class: **UBR**, ABR;
- arrival patterns: **equally spaced frames**, self-similar, random;
- frame length: 64 B, **1518 B**, **9188 B** or 64 kB, variable;

Values in bold indicate traffic characteristics for which measurement tests must be performed and for which throughput values must be reported.

3.2. Frame Latency

3.2.1. Definition

MIMO latency (Message-In Message-Out) is a general definition of the latency that applies to an ATM switch or a group of ATM switches. It is defined as follows:

$$\text{MIMO latency} = \min \{ \text{LILO latency}, \text{FILO latency} - \text{NFOT} \}$$

where:

- LILO latency = Time between the last-bit entry and the last-bit exit
- FILO latency = Time between the first-bit entry and the last-bit exit
- NFOT = Nominal frame output time

The nominal frame output time is defined as:

$$\text{NFOT} = \text{Frame input time} \times \text{Input link rate} / \text{Output link rate}$$

where:

- Frame input time = Time between the first-bit entry and the last-bit entry

The following is an equivalent definition for MIMO latency:

$$\text{MIMO latency} = \begin{cases} \text{LILO latency} & \text{if input link rate} \leq \text{output link rate} \\ \text{FILO latency} - \text{NFOT} & \text{if input link rate} \geq \text{output link rate} \end{cases}$$

It should be noted that when the input link rate is equal to the output link rate:

$$\text{MIMO latency} = \text{LILO latency} = \text{FILO latency} - \text{NFOT}$$

The MIMO latency is a general definition that applies even when the frames are discontinuous at the input and/or output or when the input and output rates are different.

To measure MIMO latency for a given frame, the time of occurrence for the following three events need to be recorded:

- First-bit of the frame enters into the SUT,
- Last-bit of the frame enters into the SUT,
- Last-bit of the frame exits from the SUT.

The time between the first and the second events is FILO latency and the time between the second and third events is LILO latency.

NFOT can be calculated given the cell pattern of the test frame on input (which includes a number of cells of the test frame and duration of idle intervals, if any, and/or number of cells from other frames, if any, between the first cell and the last cell during input transmission of the test frame), and rates of input and output links. Note that for contiguous frames on input:

$$\text{Frame input time} = \text{Frame Size} / \text{Input link rate}$$

and then it follows:

$$\text{NFOT} = \text{Frame Size} / \text{Output link rate}$$

Substituting LILO latency, FILO latency and NFOT in the MIMO latency formula would give the frame latency of the SUT.

Appendix A (Section A.2.) presents an explanation of MIMO latency and its justification.

3.2.2. Frame Delay and Cell Level Data

Contemporary ATM monitors provide measurement data only at the cell level, e.g., cell transfer delay (CTD) and cell inter-arrival time. This data is sufficient to calculate MIMO frame latency as follows.

If the input link rate is less than or equal to the output link rate, then:

$$\text{MIMO latency} = \text{Last cell's transfer delay} - (\text{Last cell's input transmit time} + \text{Monitor overhead})$$

where:

- the cell transfer delay is the amount of time it takes for a cell to begin leaving the ATM test system and to finish arriving at the ATM test system, i.e. the time between the first bit out and the last bit in;

- the cell input transmit time is the time to transmit one cell into the input link. It can be easily calculated;
- the monitor overhead is the overhead introduced by the ATM monitor when measuring CTD and it is usually non zero. It can be calculated as difference between the measured cell transfer delay for the case of closed loop on the ATM monitor and the theoretical value for the cell transmit time plus any propagation delay.

Thus, to calculate MIMO latency when the input link rate is less than or equal to the output link rate, it is sufficient to measure the transfer delay of the last cell of a frame.

If the input link rate is greater than or equal to the output link rate, then:

$$\text{MIMO latency} = \text{FIFO latency} + \text{Frame output time} - \text{NFOT}$$

where:

- FIFO latency
 - = Time between the first-bit entry and the first-bit exit
 - = First cell's transfer delay – (First cell's output transmit time + Monitor overhead)
- Frame output time
 - = Time between the first-bit exit and the last-bit exit
 - = First cell to last cell inter-arrival time + Last cell's output transmit time
- the cell output transmit time is the time to transmit one cell into the output link. It can be easily calculated.
- the cell inter-arrival time is the time between arrival of the first bit of the first cell and the first bit of the last cell.

Thus, to calculate MIMO latency when the input link rate is greater than or equal to the output link rate, it is necessary to measure the first cell transfer delay and the inter-arrival time between the first cell and the last cell of a frame.

Appendix A (Section A.3.) presents derivations of expressions for MIMO latency calculation based on cell level data.

3.2.3. Units

The latency should be specified in μsec .

3.2.4. Statistical Variations

For the given foreground traffic and background traffic, the required times and/or delays, needed for MIMO latency calculation, are recorded for p frames, according to the procedures described in 3.2.5. Here p is a parameter and its default (and the minimal value) is 100.

Let M_i be the MIMO latency of the i th frame. Note that MIMO latency is considered to be infinite for lost or corrupted frames. The mean and standard errors of the measurement are computed as follows:

$$\text{Mean MIMO latency} = (\sum M_i) / p$$

$$\text{Standard deviation of MIMO latency} = (\sum(M_i - \text{mean MIMO latency})^2) / (p-1)$$

$$\text{Standard error} = \text{standard deviation of MIMO latency} / p^{1/2}$$

Given the mean and the standard error, the users can compute a $100(1-\alpha)$ -percent confidence interval as follows:

$$100(1-\alpha)\text{-percent confidence interval} = (\text{mean} - z \times \text{standard error}, \text{mean} + z \times \text{Standard error})$$

Here, z is the $(1-\alpha/2)$ -quantile of the unit normal variate. For commonly used confidence levels, the quantile values are as follows:

Confidence	α	Quantile
90%	0.1	1.615
99%	0.01	2.346
99.9%	0.001	3.291

The value of p can be chosen differently from its default value to obtain the desired confidence level.

3.2.5. Measurement Procedures

For MIMO latency measurements, it is first necessary to establish one VCC (or VPC) used only by foreground traffic, and a number of VCCs or VPCs used only by background traffic. Then, the background traffic is generated. Characteristics of a background traffic are described in section 3.2.7. When flow of the background traffic has been established, the foreground traffic is generated. Characteristics of a foreground traffic are specified in section 3.2.6. After the steady state flow of foreground traffic has been reached the required times and/or delays needed for MIMO latency calculation are recorded for p consecutive frames from the foreground traffic, while the flow of background traffic continue uninterrupted. The entire procedure is referred to as one measurement run.

3.2.6. Foreground traffic

MIMO latency depends upon several characteristics of foreground traffic. These include the type of foreground VCC, service class, arrival patterns, frame length, and input rate.

The foreground VCC can be a permanent or switched, virtual path or virtual channel connection, established between ports on the same network module of the switch, or between ports on different network modules, or between ports on different switching fabrics.

For the UBR service class, the foreground traffic consists of equally spaced frames of fixed length. Measurements are performed on AAL payload sizes of 64 B, 1518 B, 9188 B and 64 kB. Variable length frames and other arrival patterns (e.g. self-similar) are under study. ABR service class is also under study.

Input rate of foreground traffic is expressed in the effective bits/sec, counting only bits from AAL payload excluding the overhead introduced by the ATM technology and transmission systems.

The first measurement run is performed at the lowest possible foreground input rate (for the given test equipment). For later measurement runs, the foreground load is increased up to the point when losses in the traffic occur or up to the full foreground load (FFL). FFL is equal to the lesser of the input and the output link rates used by the foreground VCC. Suggested input rates for the foreground traffic are: 0.5, 0.75, 0.875, 0.9375, 0.9687, ..., i.e. $1 - 2^{-k}$, $k = 1, 2, 3, 4, 5, \dots$, of FFL.

3.2.7. Background Traffic

Background traffic characteristics that affect frame latency are the type of background VCCs, connection configuration, service class, arrival patterns (if applicable), frame length (if applicable) and input rate.

Like the foreground VCC, background VCCs can be permanent or switched, virtual path or channel connections, established between ports on the same network module on the switch, or between ports on different network modules, or between ports on different switching fabrics. To avoid interference on the traffic generator/analyzer equipment, background VCCs are established in such way that they do not use the input link or the output link of the foreground VCC in the same direction.

For a SUT with w ports, the background traffic can use $(w-2)$ ports, not used by the foreground traffic, for both input and output. The port with the input link of the foreground traffic can be used as an output port for the background traffic. Similarly, the output port of the foreground traffic can be used as an input port for the background traffic. Overall, background traffic can use an equivalent of $n=w-1$ ports. The maximum

background load (MBL) is defined as the sum of rates of all links, except the one used as the input link for the foreground traffic, in the maximum possible switch configuration.

A SUT with $w (=n+1)$ ports is measured for the following background traffic connection configurations:

- n-to-n straight, with n background VCCs, (Figure 3.2.a);
- n-to-($n-1$) full cross, with $n \times (n-1)$ background VCCs. (Figure 3.2.b);
- n-to- m partial cross, $1 \leq m \leq n-1$, with $n \times m$ background VCCs. (Figure 3.2.c);
- 1-to-($n-1$), with one (multicast) background VCC. (Figure 3.2.e);

Use of the 1-to-($n-1$) connection configuration for the background traffic is under study.

The following service classes, arrival patterns (if applicable) and frame lengths (if applicable) are used for the background traffic:

- UBR service class: Traffic consists of equally spaced frames of fixed length. Measurements are performed at AAL payload size of 64 B, 1518 B, 9188 B and 64 kB. This is a case of bursty background traffic with priority equal to or lower than that of the foreground traffic. Variable length frames and other arrival patterns (e.g. self-similar) are for further study.
- CBR service class: Traffic consists of a contiguous stream of cells at a given rate. This is a case of non-bursty background traffic with priority higher than that of the foreground traffic.
- VBR and ABR service classes are under study.

Input rate of the background traffic is expressed in the effective bits/sec, counting only bits from frames excluding the overhead introduced by the ATM technology and transmission systems.

In the cases of n-to-n straight, n-to-($n-1$) full cross and n-to- m partial cross connection configurations, measurement are performed at input rates of 0, 0.5, 0.75, 0.875, 0.9375, 0.9687, ... ($1 - 2^{-k}$, $k = 0, 1, 2, 3, 4, 5, \dots$) of MBL. The required traffic load is obtained by loading each input link by the same fraction of its input rate. In this way, the input rate of background traffic can also be expressed as a fraction (percentage) of input link rates.

3.2.8. Guidelines For Scaleable Test Configurations

Scaleable test configurations for MIMO latency measurements require only one ATM test system with two generator/analyzer pairs. Figure 3.5 presents the test configuration with an ATM switch with eight ports ($w=8$). There are two links between the ATM monitor and the switch, and they are used in one direction by the background traffic and in the another direction by the foreground traffic, as indicated. The other six ($w-2$) ports of the switch are used only by the background traffic and they have external loopbacks. A loopback on a given port causes the frames transmitted over the output of the port to be received by the input of the same port.

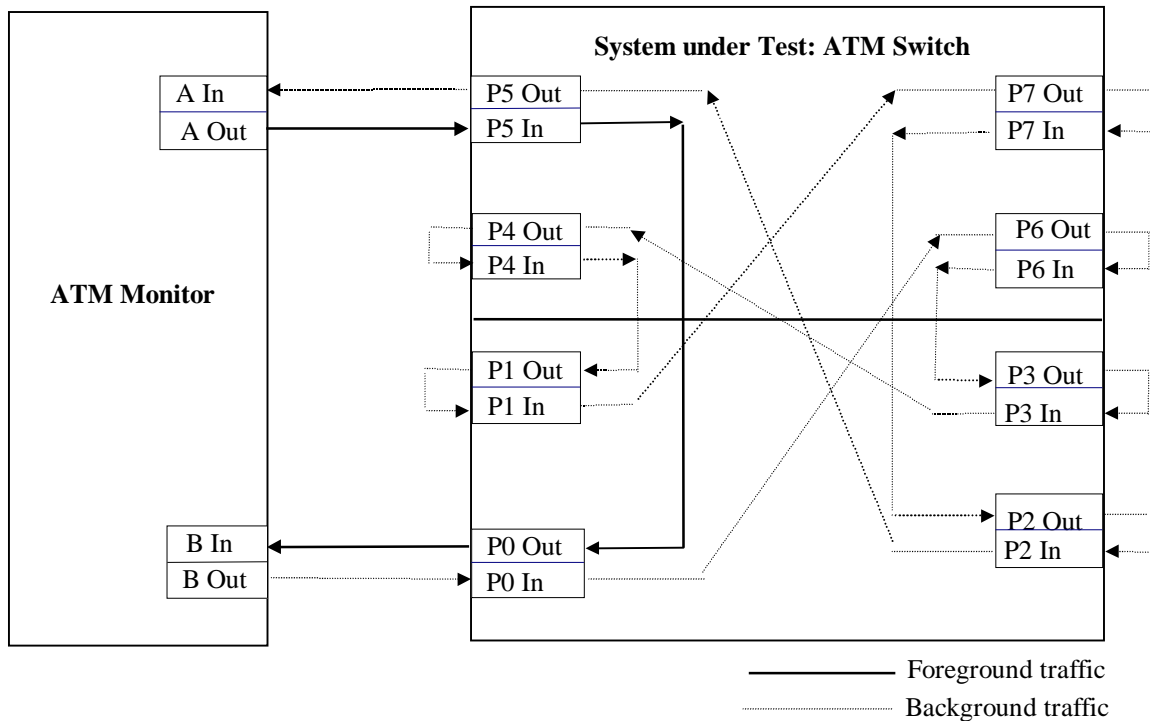

Figure 3.5: A scalable test configuration for measurements of MIMO latency using only two generator analyzer pairs with 8-port switch and 7-to-7 straight configuration for background traffic

Figure 3.5 shows a 7-to-7 straight connection configuration for the background traffic. The n -to- $(n-1)$ full cross configuration and the n -to- m partial cross configurations can also be similarly implemented.

The test configuration shown assumes two network modules in the switch with ports P0-P3 in one network module and ports P4-P7 in the another network module. Here, the foreground VCC and background VCCs are established between ports in different network modules.

It should be noted that in the proposed test configurations, because of loopbacks, only permanent VCCs or VPCs can be established.

It should also be realized that in test configurations, if all link rates are not identical, it is not possible to generate background traffic (without losses) equal to MBL. The maximum background traffic input rate in those cases equals $(n-1) \times$ lowest link rate. Only in the case where all link rates are identical is it possible to obtain MBL level without losses in background traffic.

If the link rates are different, it is possible to obtain MBL in the n -to- n straight case, but background traffic will have losses. In this case, the foreground traffic should use the lowest rate port in the switch as the input, while the highest rate port in the switch should

be used as the output. The background traffic enters the SUT through the highest rate port and passes successively through ports of decreasing speeds. At the end, the background traffic exits the switch through the lowest rate port.

3.2.9. Reporting results

Reported results should include detailed description of the SUT, such as the number of ports, rate of each port, number of ports per network module, number of network modules, number of network modules per fabric, number of fabrics, the software version and any other relevant information.

Values of the mean and the standard error of MIMO latency are reported along with values of foreground and background traffic characteristics for each measurement run.

The list of foreground and background traffic characteristics and their possible values are now provided:

Foreground traffic:

- type of foreground VCC: permanent virtual path connection, switched virtual path connection, **permanent virtual channel connection**, switch virtual channel connection;
- foreground VCC established: between ports inside a network module, **between ports on different network modules**, between ports on different switching fabrics;
- service class: **UBR**, ABR;
- arrival patterns: **equally spaced frames**, self-similar, random;
- frame length: 64 B, **1518 B**, **9188 B** or 64 kB, variable;
- full foreground load (FFL);
- input rate: **the lowest rate possible for the given test equipment**, and 0.5, **0.75**, 0.875, 0.9375, 0.9687, ..., (i.e., $1 - 2^{-k}$, $k = 1, 2, 3, 4, 5, \dots$) of FFL.

Background traffic:

- type of background VCC's: permanent virtual path connections, switched virtual path connections, **permanent virtual channel connections**, switch virtual channel connections;
- foreground VCCs established: between ports inside a network module, **between ports on different network modules**, between ports on different switching fabrics, some combination of previous cases;
- connection configuration: n-to-n straight, n-to-(n-1) full cross, **n-to-m partial cross with $m = 2, 3, 4, \dots, n-1$** ;
- service class: **UBR**, **CBR**, ABR, VBR;
- arrival patterns (when applicable): **equally spaced frames**, self-similar, random;
- frame length (when applicable): 64 B, 1518 B, **9188 B**, 64 kB, variable;
- maximum background load (MBL);

- input rate: **0**, 0.5, 0.75, **0.875**, 0.9375, 0.9687, ... (i.e., $1 - 2^{-k}$, $k = 0, 1, 2, 3, 4, 5, \dots$) of MBL.

Values in bold indicate traffic characteristics for which measurement tests must be performed and for which MIMO latency values must be reported.

Appendix A: MIMO Latency

A.1. Introduction

In the case of a single bit, the latency is generally defined as the time between the instant the bit enters the system to the instant the bit exits from the system. For an illustration of a single bit case see Figure A.1.

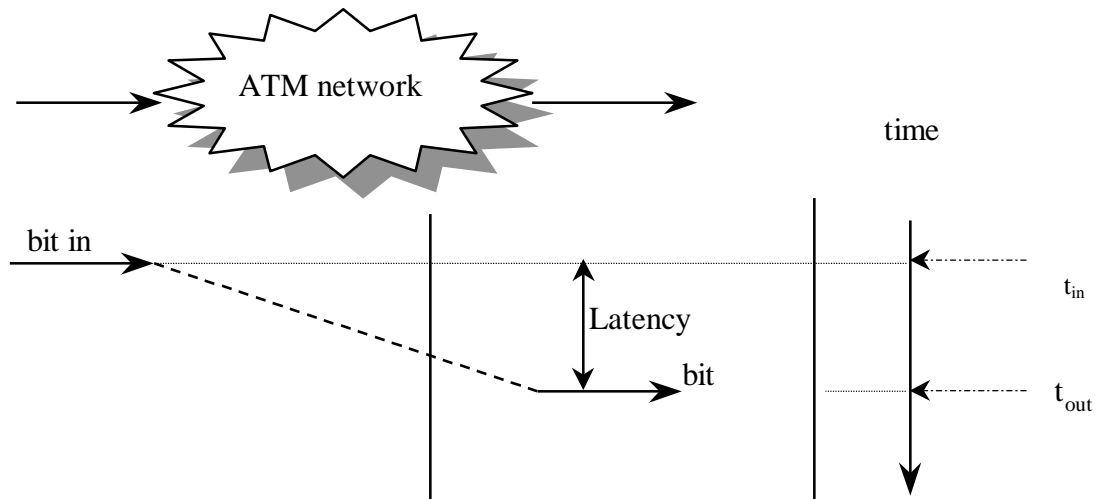

Figure A.1: Latency for a single bit

For multi-bit frames, the usual way to define a frame latency is to use one of the following four definitions:

- FIFO latency: Time between the first-bit entry and the first-bit exit
- LILO latency: Time between the last-bit entry and the last-bit exit
- FILO latency: Time between the first-bit entry and the last-bit exit
- LIFO latency: Time between the last-bit entry and the first-bit exit

Unfortunately, none of the above four metrics apply to an ATM network (or switch) since:

- an ATM switch does cell-switching, i.e. it transmits a received cell of any frame without waiting for any other cells of that frame to arrive and
- the frames are not always sent or received contiguously, i.e., there may be idle periods, idle cells or cells of other frames between cells of a test frame either on input and/or on output.

In the rest of this appendix, it is assumed that the duration of any idle period (between cells of a test frame) is always an integral number of cell times. Thus, such periods can be viewed as sequences of one or more idle cells. This assumption makes further presentation easier without any loss of generality.

Both idle cells and cells of other frames between cells of a test frame are shown as gaps. If input and output rates are different then the duration of each gap on input is different from a duration of each gap on output.

Figure A.2 illustrates different latencies of an ATM switch (network) with the input link rate higher than the output link rate for a test frame consisting of 3 cells. Note the different gaps on input and output. On input, there are two gaps after the first cell of the frame, followed by two remaining cells of the frame. On output, there is only one gap after the first cell and then two gaps between the second and the third cell of the frame.

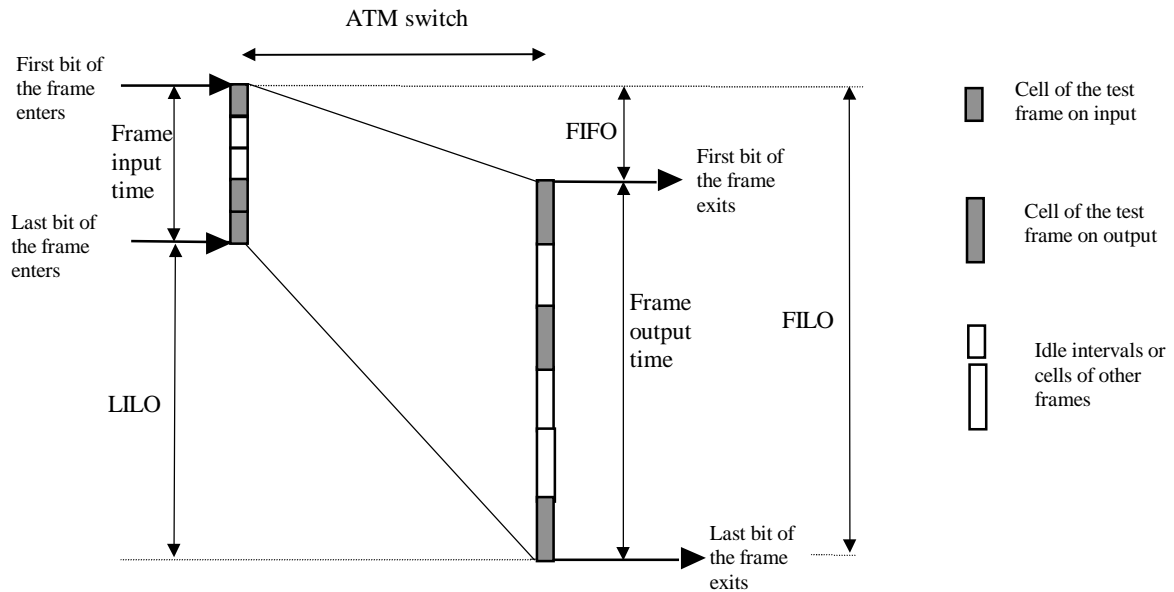

Figure A.2: Latency metrics

Figure A.2 does not show LIFO latency, because in the illustrated case, the first bit (cell) exits before the last bit (cell) enters. Consequently, LIFO latency is negative. Because the frame clearly experiences some positive delay, LIFO latency is not a good indicator of the switch latency. For this reason, LIFO latency will not be considered further.

Note that FILO latency can be computed from LILO latency given the frame input time:

$$\text{FILO latency} = \text{LILO latency} + \text{Frame input time}$$

It is clear that LILO is a preferred metric in this case, since it is independent of the frame input time, while FILO would be different for each frame input time. For this reason FILO is not a good measure of switch latency.

In the next section, we justify the MIMO latency definition as defined in Section 3.2.1. We systematically consider all possible cases comparing FIFO latency, LILO latency and MIMO latency; and we show that MIMO latency is the correct metric in all cases, whereas other metrics apply to some cases but give incorrect results in others. The last section of this appendix shows how to calculate MIMO latency based on cell level data.

A.2. MIMO latency justification

In this section, we consider only cases where a test frame is discontinuous on both input and output, i.e. cases with gaps between the cells of a test frame. It should be noted that cases with contiguous frames on input and/or output are special cases of discontinuous frames with no gaps.

Depending upon the number of gaps on input and output, we have three possibilities:

- *No change in gaps*: The number of gaps on output is same as that on input.
- *Expansion of gaps*: The number of gaps on output is larger than that on input.
- *Compression of gaps*: The number of gaps on output is less than that on input.

The nine cases and the applicability of the three metrics (FIFO latency, LILO latency and MIMO latency) to those cases are shown in Table A.1.

Table A.1: Applicability of Various Latency Definitions

No.	Case	FIFO	LILO	MIMO
1a	Input rate = Output rate, no change in gaps	√	√	√
1b	Input rate = Output rate, expansion of gaps	×	√	√
1c	Input rate = Output rate, compression of gaps	×	√	√
2a	Input rate < Output rate, no change in gaps	×	√	√
2b	Input rate < Output rate, expansion of gaps	×	√	√
2c	Input rate < Output rate, compression of gaps	×	√	√
3a	Input rate > Output rate, no change in gaps	√	×	√
3b	Input rate > Output rate, expansion of gaps	×	×	√
3c	Input rate > Output rate, compression of gaps	×	×	√

√⇒The metric gives a valid result.

×⇒ The metric gives an invalid result.

For each case we present a scenario similar to one in Figure A.2, but with simplified labeling. Each case includes one scenario with a test frame exercising a nonzero (positive) latency and (if possible) another scenario with a test frame exercising a zero-latency. We refer to a switch with positive frame latency as a non-zero (positive) delay switch and to a switch with a zero frame latency as a zero delay switch. The cases with a zero-delay switch are especially useful to verify the validity of a latency definition, because the switch delay is known in advance (equal to zero).

It should be noted that it is actually possible to have a negative frame latency and we refer to such switch as a speed-up (negative delay) switch. That scenario is only possible in the case of Input rate > Output rate and compression of gaps (Case 3c).

Case 1a: Input rate = Output rate, No Change in Gaps

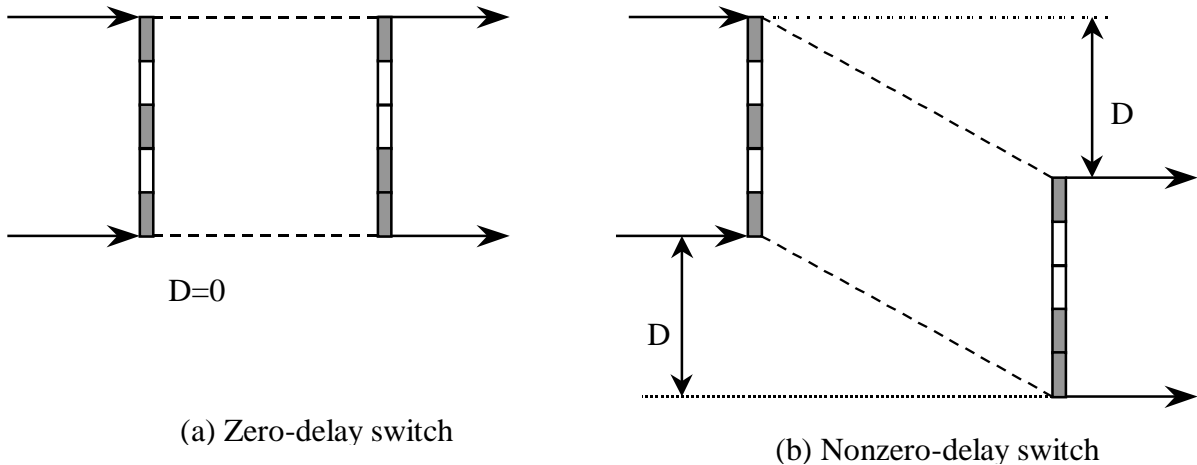

Figure A.3

In both scenarios, the pattern of gaps on input is made purposely different from the pattern of gaps on output. This is just to illustrate the point that it is the total gap that matters, and not their locations within the test frame. In the given scenarios, the total number of gaps is 2 cells on both input and output.

In this case, the switch delay D is given by:

$$D = \text{First bit latency} = \text{Last bit latency}$$

Here, we have:

- FIFO latency = $D \Rightarrow$ FIFO latency is correct.
- LILO latency = $D \Rightarrow$ LILO latency is correct.
- Input rate = Output rate & FILO latency – Frame input time = D
 \Rightarrow MIMO latency = $\min \{ \text{LILO latency}, \text{FILO latency} - \text{Frame input time} \}$
 $= \min \{ D, D \} = D$
 \Rightarrow MIMO latency is correct.

Case 1b: Input Rate = Output Rate, Expansion of Gaps

A zero-delay switch with expansion of gaps is not possible. Therefore, only a non-zero delay switch is shown in Figure A.4.

In this case, the switch delay D is given by:

$$D = \text{Last bit latency} = \text{First bit latency} + \text{Time of additional gaps on output}$$

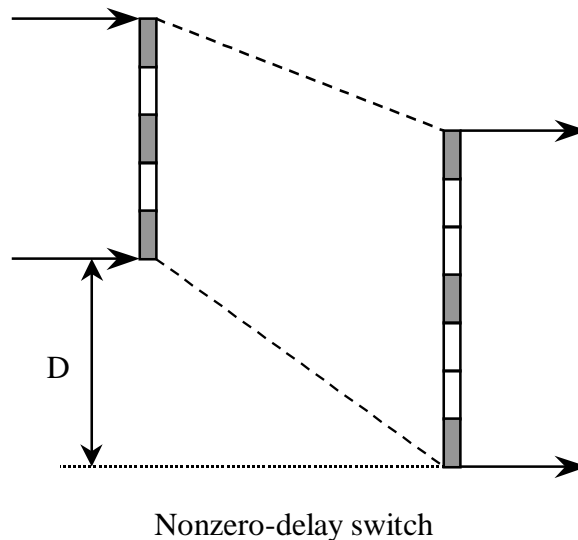

Figure A.4

Here, we have:

- FIFO latency $< D \Rightarrow$ FIFO latency is incorrect; FIFO latency does not reflect expansion of gaps. It remains the same even when there is a large expansion.
- LILO latency $= D \Rightarrow$ LILO latency is correct.
- Input rate = Output rate & FILO latency – Frame input time = D
 \Rightarrow MIMO latency = $\min \{ \text{LILO latency}, \text{FILO latency} - \text{Frame input time} \}$
 $= \min \{ D, D \} = D$
 \Rightarrow MIMO latency is correct.

Case 1c: Input Rate = Output Rate, Compression of Gaps

In this case, shown in Figure A.5, the switch delay D is given by:

$$D = \text{Last bit latency} = \text{First bit latency} - \text{Time of additional gaps on input}$$

Here, we have:

- FIFO latency $> D \Rightarrow$ FIFO latency is incorrect; FIFO latency is incorrect because it does not reflect compression of gaps.

- LIFO latency = $D \Rightarrow$ LIFO latency is correct.
- Input rate = Output rate & FIFO latency – Frame input time = D
 \Rightarrow MIMO latency = $\min \{ \text{LIFO latency}, \text{FIFO latency} - \text{Frame input time} \}$
 $= \min \{ D, D \} = D$
- MIMO latency is correct

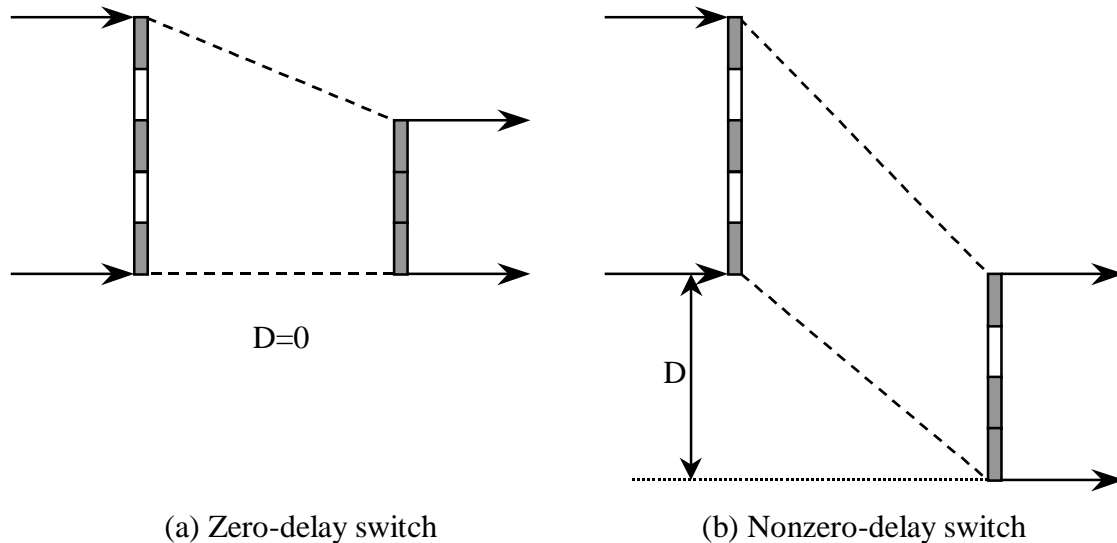

Figure A.5

Case 2a: Input Rate < Output Rate, No change in Gaps

In this case, shown in Figure A.6, the switch delay D is given by:

$$D = \text{Last bit latency}$$

Here, we have:

- FIFO latency $> D \Rightarrow$ FIFO latency is incorrect; FIFO latency varies by changing the output rate and not changing the switch (and its delay) otherwise. So, FIFO latency does not correctly represent the switch latency.
- LIFO latency = $D \Rightarrow$ LIFO latency is correct.
- Input rate < Output rate
 \Rightarrow FIFO latency – Frame input time \times Input rate / Output rate = $M > D$
 \Rightarrow MIMO latency = $\min \{ \text{LIFO latency}, M \} = D$
 \Rightarrow MIMO latency is correct.

If idle cells are considered part of the test frame, then this as well as all other cases of “no change in gaps” becomes the same as if the frame is contiguous. It is obvious that FIFO latency is equally incorrect for contiguous frames.

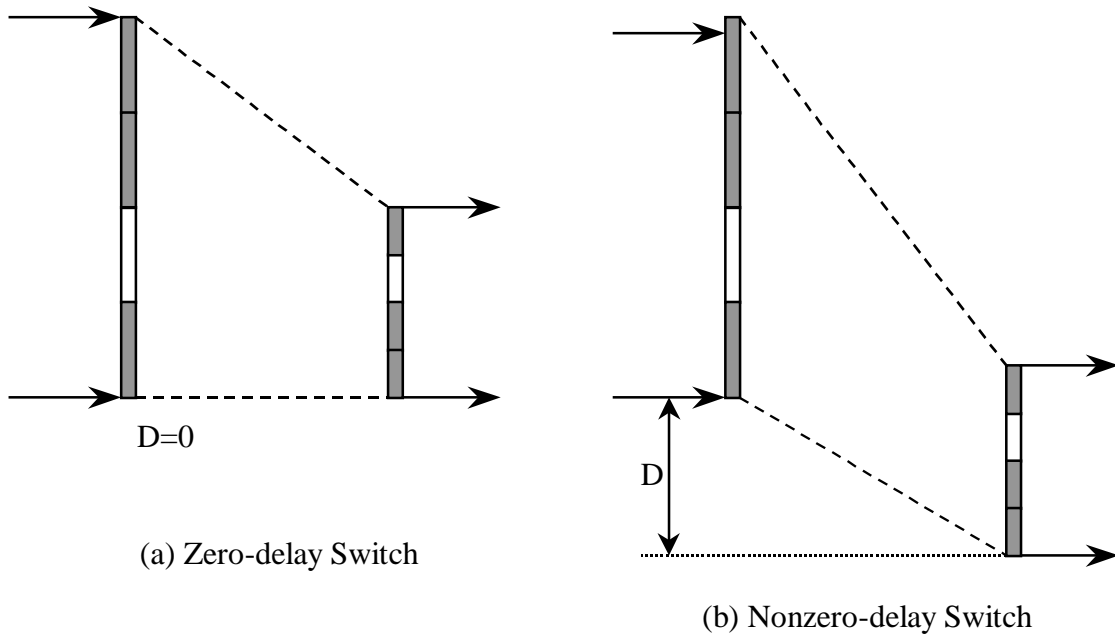

Figure A.6

Case 2b: Input Rate < Output Rate, Expansion of Gaps

In this case, shown in Figure A.7, the switch delay D is given by:

$$D = \text{Last bit latency}$$

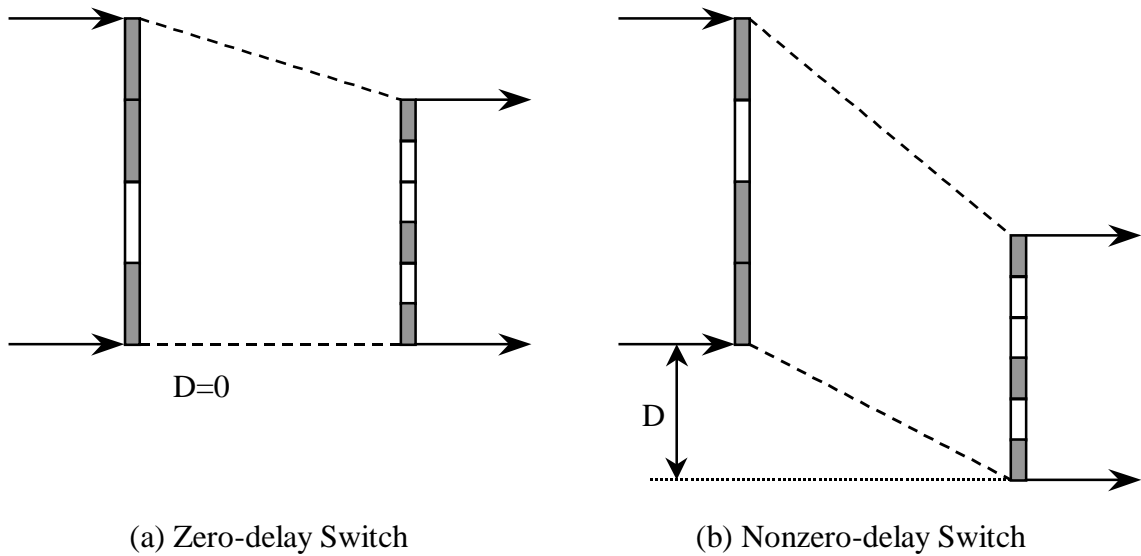

Figure A.7

Here, we have:

- FIFO latency is incorrect because it varies as the output rate (or delay) in the switch is changes, without any other changes.
- It should be noted that in this case, with a given input rate and a given number of gaps on input, it is possible to produce scenarios with an appropriate output rate and an appropriate number of gaps on output such that $\text{FIFO latency} > D$, $\text{FIFO latency} < D$ or even $\text{FIFO latency} = D$, all without changing switch characteristics.
- LILO latency = $D \Rightarrow$ LILO latency is correct;
- Input rate $<$ Output rate
 \Rightarrow FILO latency – Frame input time \times Input rate / Output rate = $M > D$
 \Rightarrow MIMO latency = $\min \{ \text{LILO latency}, M \} = D$
 \Rightarrow MIMO latency is correct;

Case 2c: Input Rate $<$ Output Rate, Compression of Gaps

In this case, shown in Figure A.8, the switch delay D is given by:

$$D = \text{Last bit latency}$$

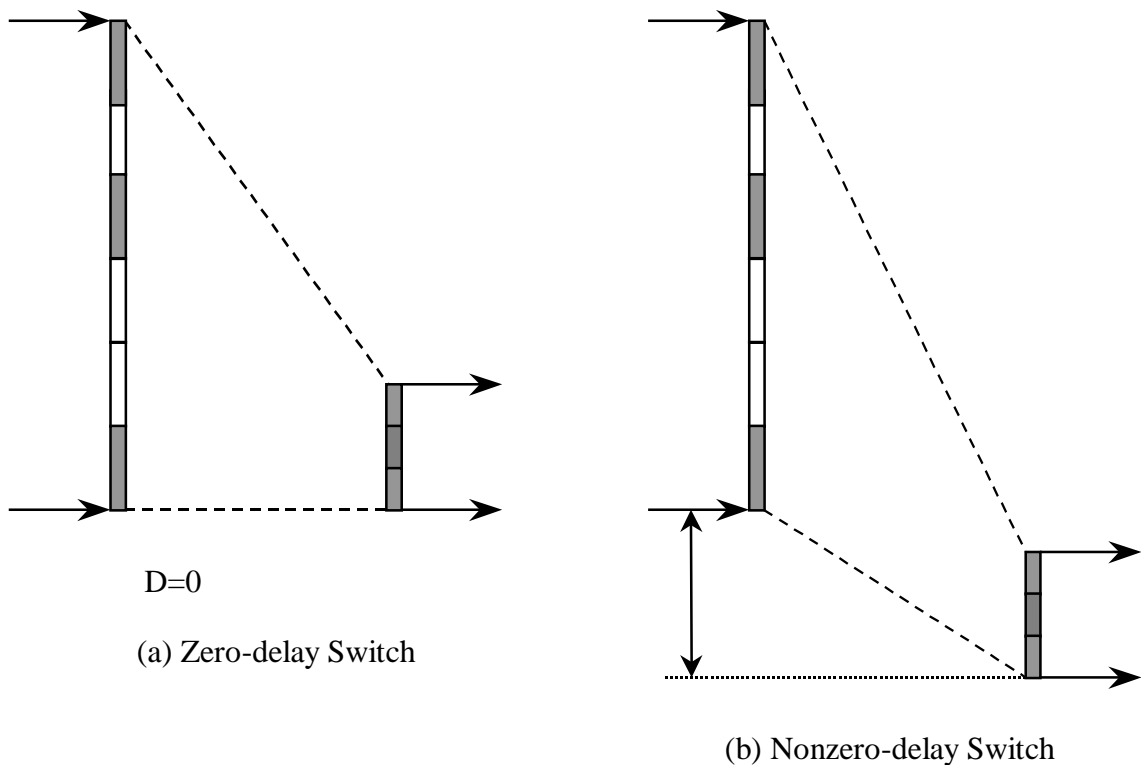

Figure A.8

Here we have:

- FIFO latency $> D \Rightarrow$ FIFO latency is incorrect; Note that, FIFO latency is affected by changing the output rate or/and the number of gaps on the output while the switch (and its delay) is unchanged.
- LILO latency $= D \Rightarrow$ LILO latency is correct.
- Input rate $<$ Output rate
 \Rightarrow FILO latency $-$ Frame input time \times Input rate / Output rate $= M = > D$
 \Rightarrow MIMO $= \min \{ \text{LILO latency}, M \} = D$
 \Rightarrow MIMO latency is correct.

Case 3a: Input Rate $>$ Output Rate, No Change in Gaps

In this case, shown in Figure A.9, the switch delay D is given by:

$D =$ First bit latency

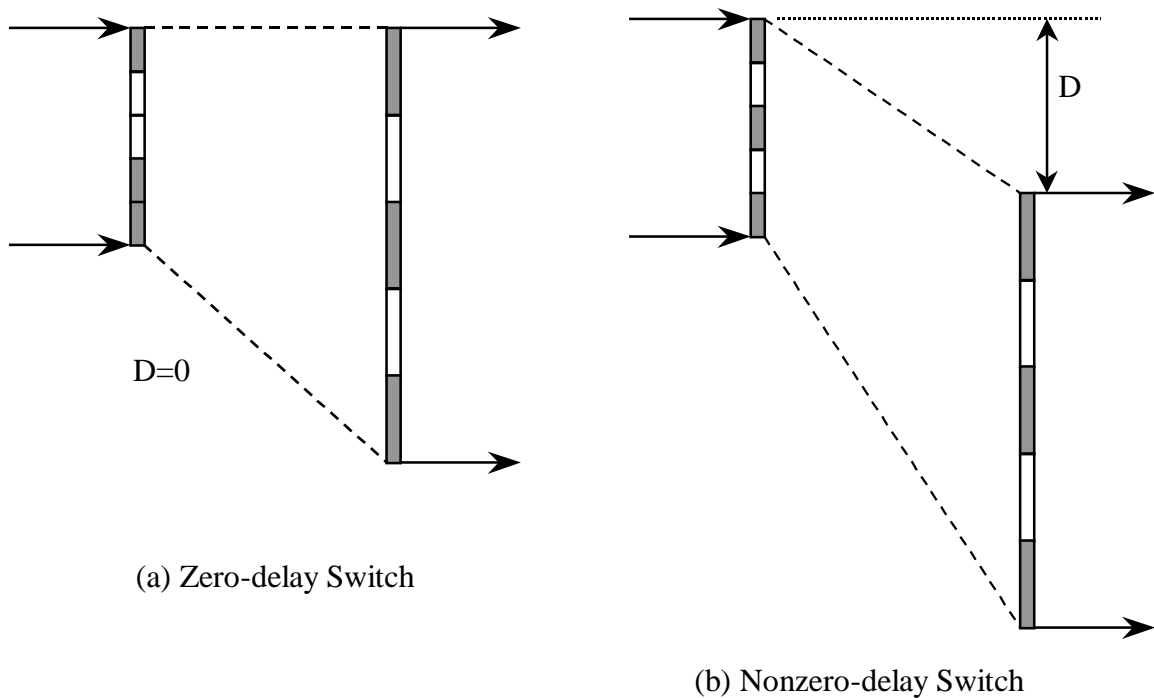

Figure A.9

Here, we have:

- FIFO latency $= D \Rightarrow$ FIFO latency is correct.
- LILO latency $> D \Rightarrow$ LILO latency is incorrect; Note that LILO latency may change by changing the output rate and without changing the switch otherwise
- FILO latency $-$ Frame input time \times Input rate / Output rate $= D$
 \Rightarrow MIMO latency $= \min \{ \text{LILO latency}, D \} = D$
 \Rightarrow MIMO latency is correct.

As it has been indicated, this case as well other cases with no change in gaps can be viewed as cases with continuous frames. It is obvious that LILO latency is equally incorrect for continuous frames.

Case 3b: Input Rate > Output Rate, Expansion of Gaps

Note that a zero-delay switch with expansion of gaps is not possible. Therefore, only the non-zero delay scenario is shown in Figure A.10.

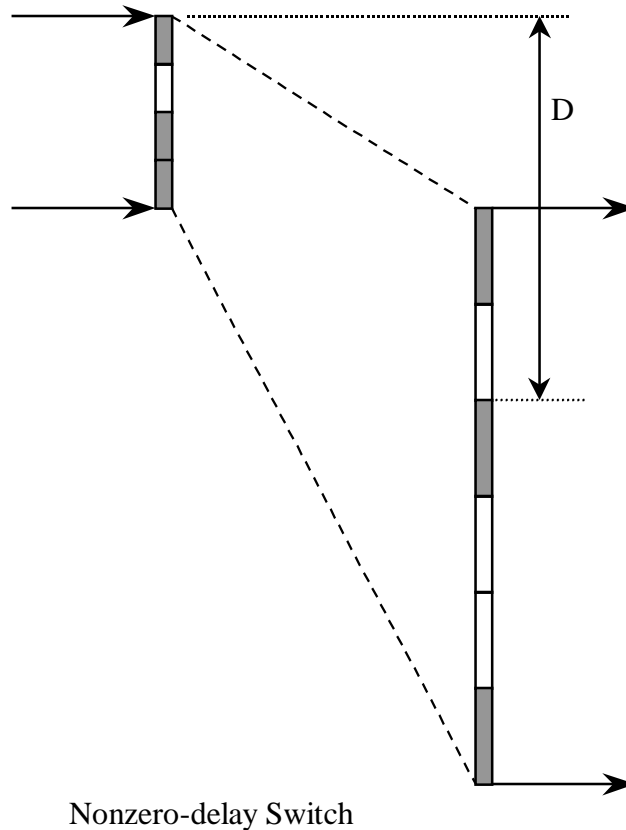

Figure A.10

In this case, the switch delay D is given by:

$$D = \text{First bit latency} + \text{Time of additional gaps on output}$$

Here we have:

- $\text{FIFO latency} < D \Rightarrow$ FIFO latency is incorrect; FIFO latency is incorrect because it does not reflect expansion of gaps. Note that FIFO latency may be even zero (the case of a zero delay for the first bit) for a nonzero-latency frame.

- LIFO latency $> D \Rightarrow$ LIFO latency is incorrect. It should be noted that while LIFO latency correctly accounts for a time of additional gaps it is incorrectly influenced by changes of output rate.
- FIFO latency – Frame input time \times Input rate / Output rate = D
 \Rightarrow MIMO latency = $\min\{\text{LIFO latency}, D\} = \min\{\text{LIFO}, D\} = D$
 \Rightarrow MIMO latency is correct.

Case 3c: Input Rate $>$ Output Rate, Compression of Gaps

Only in this case beside scenarios with a zero-delay switch and a non-zero (positive) delay switch, it is possible in addition to have a scenario with a speed-up (negative delay) switch.

In this case, it is possible to have a switch that reduces the delay of a frame by removing several gaps. Such switches are called “speedup-delay” switches. One such case is shown in Figure A.11.c. A speedup-delay switch effectively has a negative delay.

In this case, the switch delay D is given by:

$$D = \text{First bit latency} - \text{Time of missing gaps on output}$$

Three situations corresponding to three scenarios above can be distinguished:

- a zero-delay switch, where:
First bit latency = Time of missing gaps on output
- a positive-delay switch, where:
First bit latency $>$ Time of missing gaps on output
- a speedup-delay switch or a negative-delay switch, where:
First bit latency $<$ Time of missing gaps on output

Here, we have:

- FIFO latency $> D \Rightarrow$ FIFO latency is incorrect; it does not reflect compression of gaps.
- LIFO latency $> D \Rightarrow$ LIFO latency is incorrect; while LIFO latency correctly accounts for a time of additional gaps, it is incorrectly influenced by changes of output rate.
- FIFO latency – Frame input time \times Input rate / Output rate = D
 \Rightarrow MIMO latency = $\min\{\text{LIFO}, D\} = D$
 \Rightarrow MIMO latency is correct.

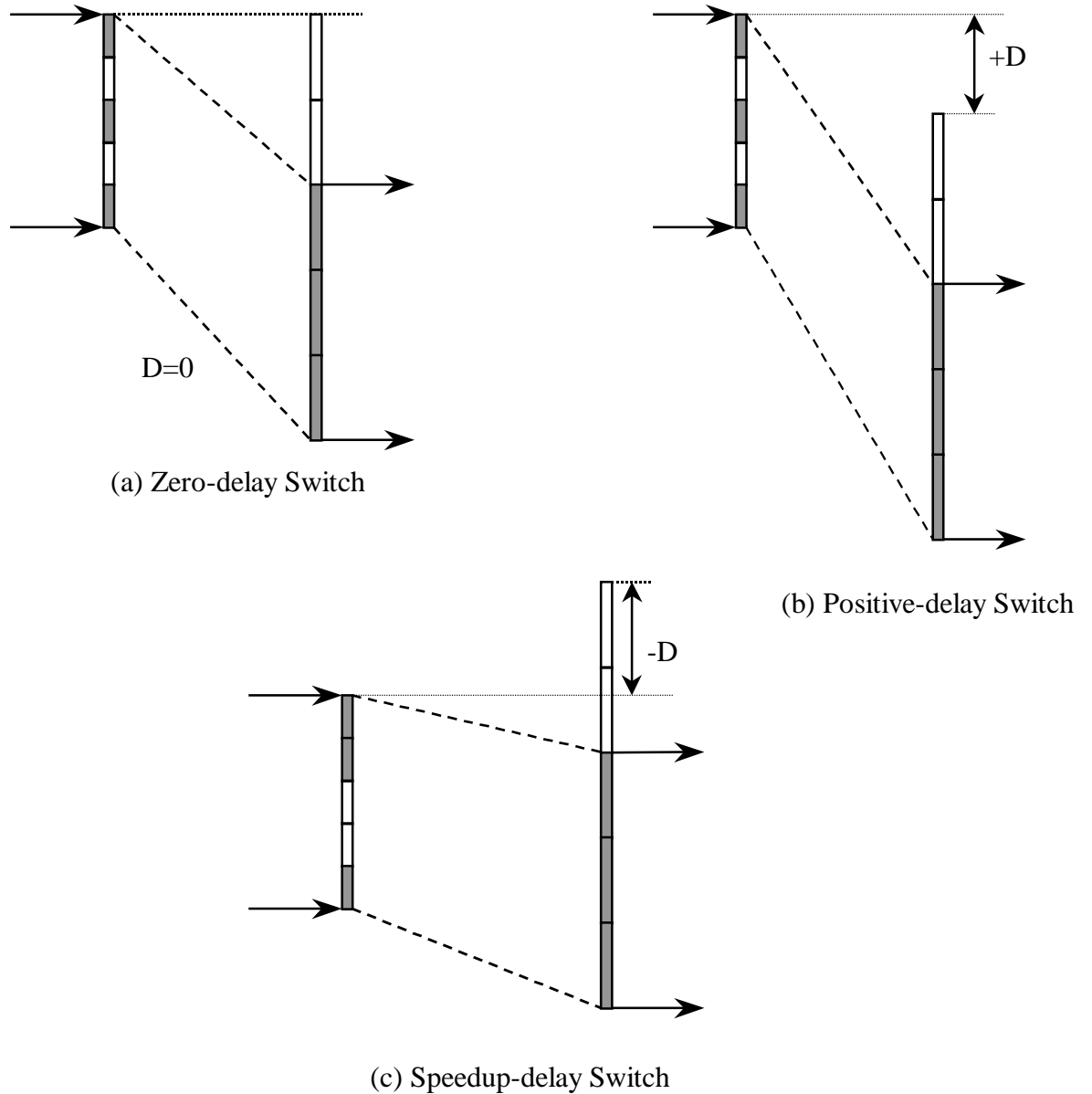

Figure A.11

A.3 MIMO latency calculation based on cell level data

Contemporary ATM monitors provide measurement data at the cell level. Considering that the definition of MIMO latency uses bit level data, in this section we explain how to calculate MIMO latency using data at the cell level.

Standard definitions of two cell level performance metrics, which are of importance for MIMO latency are:

- cell transfer delay (CTD), defined as the amount of time it takes for a cell to begin leaving the ATM monitor and to finish arriving at the ATM monitor, i.e. the time between the first bit out and the last bit in.
- cell inter-arrival time, defined as the time between arrival of the last bit of the first cell and the last bit of the second cell.

It appears that CTD values obtained by ATM monitors always include some system overhead. For example, the measured cell transfer delay for the case of closed loop on an ATM monitor is usually larger than the theoretical value for the cell transmit time (a time needed to transmit one cell over a link of given rate) plus any propagation delay. The discrepancy can be attributed to delays internal to the monitor and its time resolution. That discrepancy is called the monitor overhead, and it can be calculated as the difference between the measured cell transfer delay over a closed loop on the ATM monitor and the theoretical value for the cell transmit time.

On the other hand, it appears that inter-arrival times measured by ATM monitors are very accurate, so corrections for cell inter-arrival time values are not necessary.

The procedure for MIMO latency calculation depends upon the relative values of input and output link rates. There are two cases to consider:

- Input link rate \leq Output link rate
- Input link rate \geq Output link rate

MIMO latency calculation: Input link rate \leq Output link rate

In cases when the input link rate is less than or equal to the output link rate:

$$\text{MIMO latency} = \text{LILO latency}$$

From Figure A.12, it can be observed that:

$$\text{LILO latency} = \text{Last cell's transfer delay} - \text{Last cell's input transmit time}$$

where:

- the cell input transmit time = the time to transmit one cell into the input link.
= $53B * 8b / \text{Input link rate in bps}$

To account for the overhead in the ATM monitor, the following adjustment in LILO latency expression has to be made:

$$\text{LILO latency} = \text{Last cell's transfer delay} - (\text{Last cell's input transmit time} + \text{Monitor overhead})$$

Thus, to calculate MIMO latency when the input link rate is less than or equal to the output link rate, it is sufficient to measure the last cell's transfer delay of a frame.

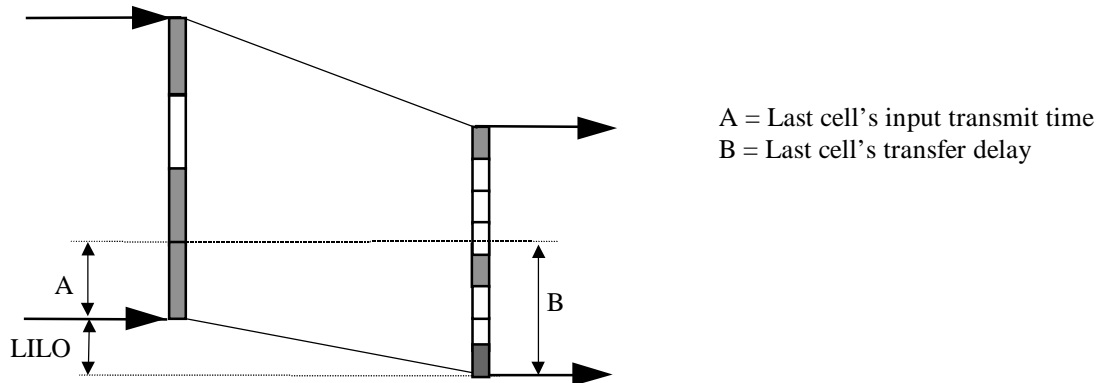

Figure A.12

MIMO Latency Calculation: Input link rate \geq Output link rate

In cases where the input link rate is greater than or equal to the output link rate:

$$\text{MIMO latency} = \text{FILO latency} - \text{NFOT}$$

NFOT can be calculated as discussed in the section 3.2.1, while FILO latency has to be obtained.

From Figure A.13, it can be observed that:

$$\text{FILO latency} = \text{FIFO latency} + \text{Frame output time}$$

Also, it can be observed that:

$$\text{FIFO latency} = \text{First cell's transfer delay} -$$

$$(\text{First cell's output transmit time} + \text{Monitor overhead})$$

$$\text{Frame output time} = \text{First cell to last cell inter-arrival time} +$$

$$\text{Last cell's output transmit time}$$

where:

- the cell output transmit time = the time to transmit one cell into the output link.
 $= 53B * 8b / \text{Output link rate in bps}$

If measurements of cell inter-arrival times are accurate, there is no need for any corrections in the FOLO expression due to the monitor overhead.

Thus, to calculate MIMO latency when the input link rate is greater than or equal to the output link rate, it is necessary to measure the first cell's transfer delay and the inter-arrival time between the first cell and the last cell of a frame.

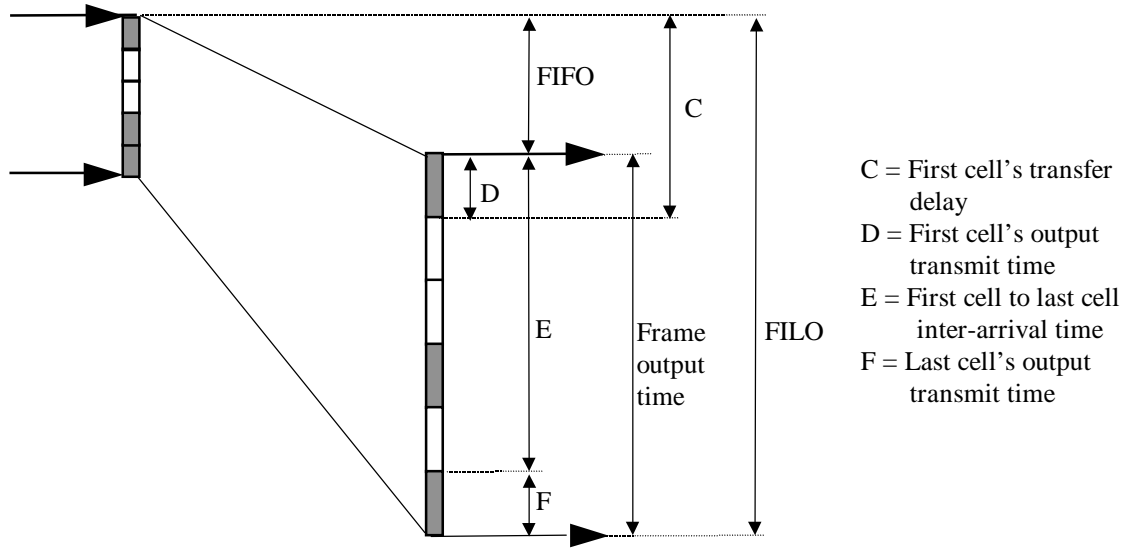

Figure A.13