

97-0617: Worst Case Buffer Requirements for TCP over ABR

Bobby Vandalore, Shiv Kalyanaraman, Raj Jain,

Rohit Goyal, Sonia Fahmy

The Ohio State University

Pradeep Samudra, Samsung Telecom America, Inc.

Contact: Jain@CIS.Ohio-State.Edu

<http://www.cis.ohio-state.edu/~jain/>



- ❑ Generating Worst Case TCP Traffic
- ❑ Analytical Results
- ❑ Simulation Results
 - ❑ Effect of number of sources
 - ❑ Effect of RTT, MSS, and other parameters

Worst Case TCP Traffic

- ❑ Sources can retain high ACR, if they send packets within 500 ms.
- ❑ Many such sources with high ACR can dump a large amount of data
- ❑ Worst case is when all the sources dump the maximum window size

Worst Case (Cont)



- ❑ Each source sends one packet every ' t ' milliseconds. $t < 500$ ms.
- ❑ After several packets, the congestion window reaches the maximum for each source
- ❑ Sources synchronize and dump large burst at the same time.
- ❑ To avoid overload initially, the sources are uniformly spaced \triangleright k th source sends its first packet at ' $k \times g$ ' μ s.

N-Source Configuration

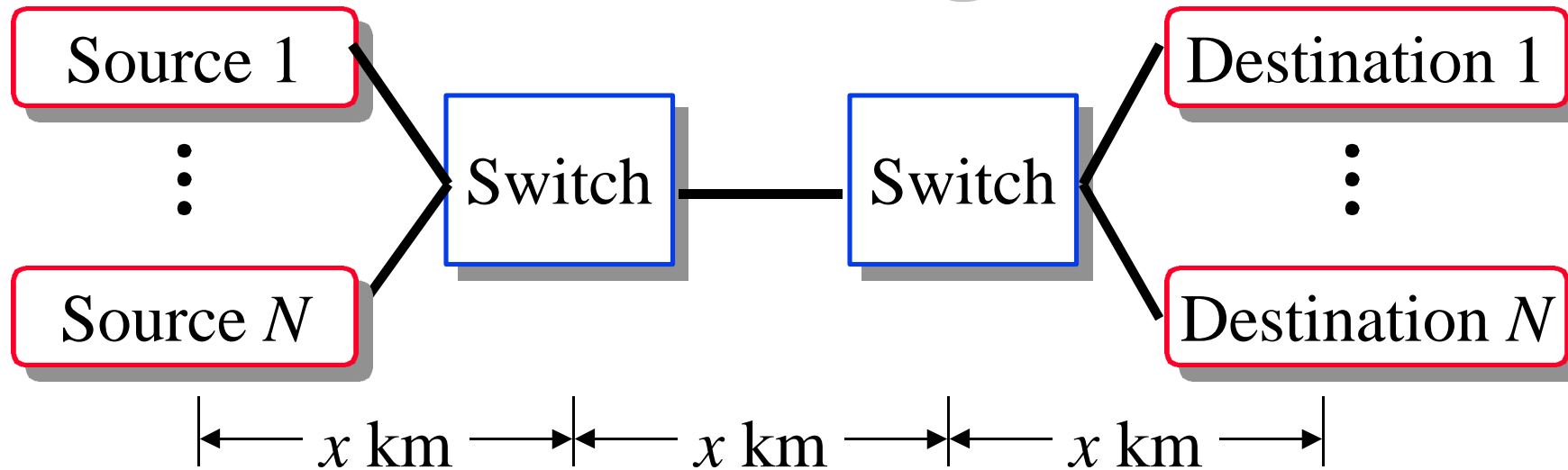

- ❑ All links 149.76 Mbps. Lengths $x = 2000, 1000$ km
- ❑ All traffic unidirectional. Worst case TCP traffic
- ❑ Parameters: # of sources = $\{2, 3, 5, 10, 20, 30, \dots, 200\}$
Infinite buffer size.

Analytical results

- Buffer requirement is reflected in maximum switch queue size.
- Let $cwnd_max$ = Max congestion window of TCP
- When $N \leq \lfloor t/g \rfloor$
 - Max Q length $\approx N \times cwnd_max/48$ (formula 1)
- When $N > \lfloor t/g \rfloor$ \uparrow 48 bytes/cell
 - Max Q length = $N * PCR * t$ (formula 2)
(PCR is peak cell rate)
- Queue length is given in terms of number of cells

Analytical results (Cont)

- With few sources, switch does not get congested even when sources reach their maximum window, ACRs can be high. Formula 1 applies here.
- With many sources, switch detects congestion and gives feedback. ACRs are low. Formula 2 applies here.

Simulation Parameters

- Source: Parameters selected to maximize ACR
TBE = 512
CDF (XDF) = 0.5
ICR = 10 Mbps
CRM (Xrm) = $\lceil \text{TBE}/\text{Nrm} \rceil$
ADTF = 0.5 sec
PCR = 149.76 Mbps, MCR = 0, RIF (AIR) = 1,
Nrm = 32, Mrm = 2, RDF = 1/512, Trm = 100ms,
TCR = 10 c/s
- Traffic: TCP/IP with worst case traffic
- Switch: ERICA+
Averaging interval = $\min\{100 \text{ cells}, 1000 \mu\text{s}\}$

Effect of Number of Sources

# TCP Srcs	Q Size (Cells)	
	Simul.	Analyt.
2	1575	2730
3	3149	4095
5	6297	6825
10	14131	13650
20	29751	27300
30	20068	11010
40	19619	14680
50	24162	18350
60	28006	22020

# TCP Srcs	Q Size (Cells)	
	Simul.	Analyt.
70	30109	25690
80	31439	29360
90	34530	33030
100	38088	36700
120	44939	44040
140	44744	51380
160	48880	58720
180	49961	66060
200	55618	73400

Effect of # of Sources (Cont)

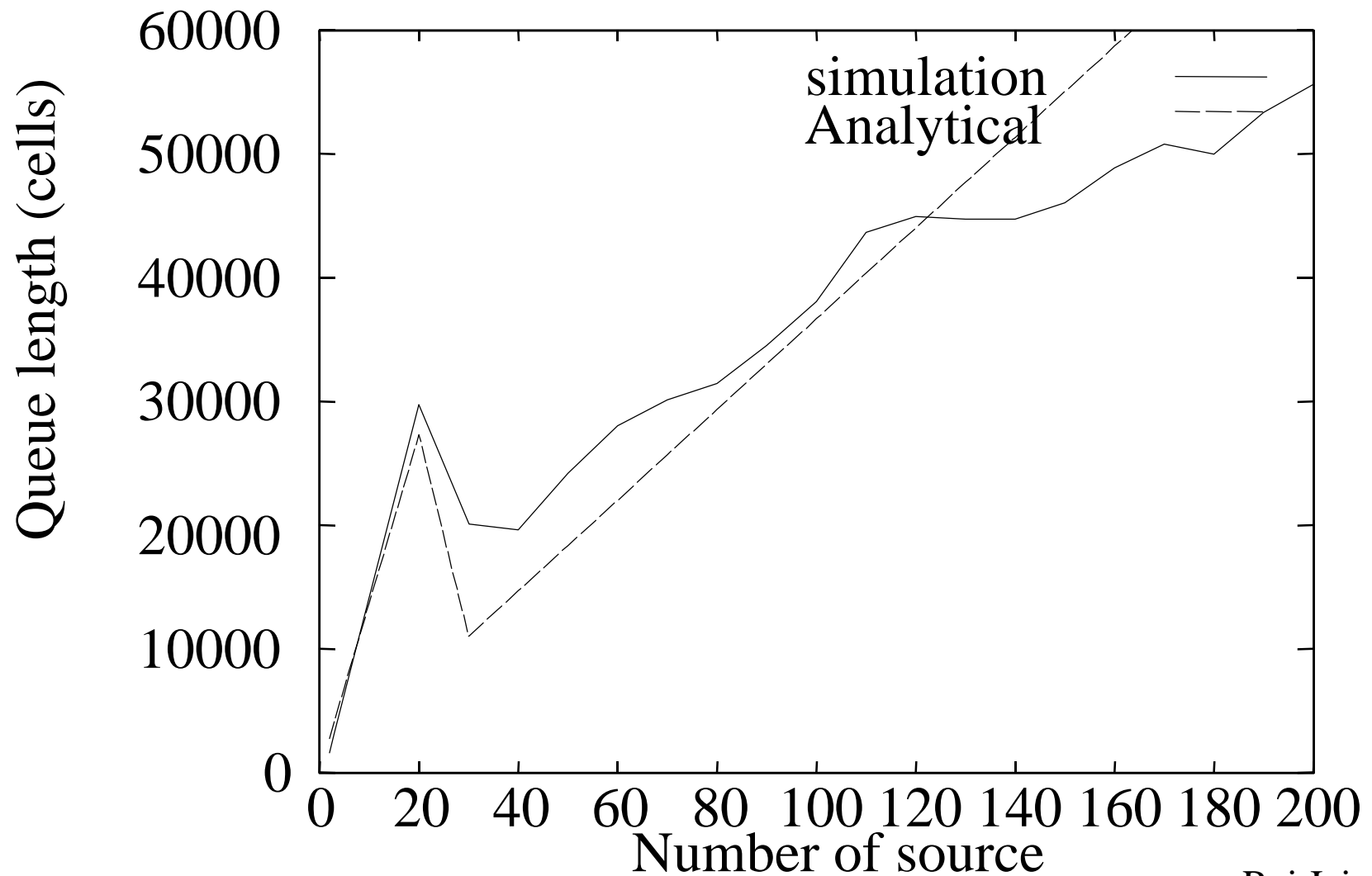

Effect of # of Rources (Cont)

- Analytical results: For $t = 1$ ms, $g = 50$ μ s, MSS = 512 bytes, cwnd_max = 64 kB
 - $Q = N * 1365$ for $N \leq 20$ (formula 1)
 - $Q = N * 367$ for $N > 20$ (formula 2)
- The zig-zag shape is due to the two formulas
- The simulation agrees well with the analytical results for $N \leq 20$.
- The maximum queues occurred at predicted times (details in the contribution)

Effect of # of Sources (Cont)

- Buffer size increases linearly as number of sources increase
- As N increases, load increases
⇒ ERICA+ controls the queue lengths ⇒ Less than analytical queue lengths

Sensitivity Analysis

#	mss/g/t/d	N=3	N=10	N=30	N=40	N=50	N=100
1	512/50/1/1000	3171	14273	20068	19619	24162	35687
2	512/50/1/2000	3171	14273	19906	27567	30872	75083
3	512/50/10/1000	3172	14274	45994	61854	77714	150453
4	512/50/10/2000	3172	14274	45994	61854	77714	150458
5	512/100/1/1000	3171	14273	19283	20080	24164	NA
6	512/100/1/2000	3171	14273	21241	32314	35961	NA
7	512/100/10/1000	3172	14274	45994	61854	77714	NA
8	512/100/10/2000	3172	14274	45994	61854	77714	NA
9	1024/50/1/1000	3040	13680	18650	18824	23542	NA
10	1024/50/1/2000	1542	5612	19131	22934	29163	NA
11	1024/50/10/1000	3040	13680	44080	59280	74480	NA
12	1024/50/10/2000	3041	13681	44081	59281	74481	NA
13	1024/100/1/1000	3040	13680	18591	19600	24314	NA
14	1024/100/1/2000	1403	5556	17471	24412	30533	NA
15	1024/100/10/1000	3040	13680	44080	59280	74480	NA
16	1024/100/10/2000	3041	13681	44081	59281	74481	NA

Sensitivity Analysis: Results

- ❑ MSS = 512, 1024 bytes, $t = 1, 10$ ms, $g = 50, 100$ μ s, Link distance = 1000, 2000 km
Two values for each of the 4 parameters \Rightarrow 16 experiments.
- ❑ Segment size does not affect queue sizes
- ❑ If the network is not overloaded then round trip time has no effect (Expt. 3 and 4)
- ❑ If the network is overloaded then a larger round trip gives larger queue lengths (Expt. 1, 2 for $N = 30, 40, 50$)

Summary

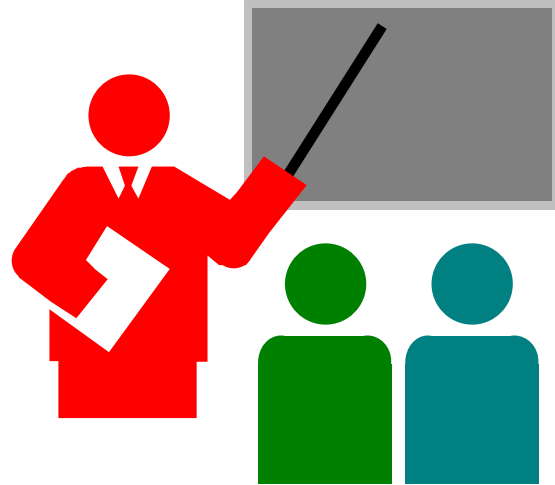

- ❑ In worst case, the buffer requirements depend on the number of sources, network congestion status (overloaded or underloaded) and round trip time
- ❑ It is not affected by maximum segment size.