

97-0424

# Guaranteed Rate for Improving TCP Performance on UBR+ over Terrestrial and Satellite Networks

Rohit Goyal, Raj Jain, Shiv Kalyanaraman, Sonia Fahmy,  
Bobby Vandalore, Xiangrong Cai  
The Ohio State University

Seong-Cheol Kim, Samsung Electronics Co. Ltd.

Sastri Kota, Lockheed Martin Telecom/Astrolink

<http://www.cis.ohio-state.edu/~jain/>



- ❑ What is Guaranteed Rate (GR) Service?
- ❑ Effect of Guaranteed Rate on UBR performance
- ❑ Results for LAN, WAN, and Satellite Networks

# Goal

- ❑ Q: Will UBR work if the available bandwidth varies significantly?
- ❑ All past results have assumed no VBR background. Fixed link capacities.
- ❑ If UBR is starved, the connections may timeout.
- ❑ Q: Does reserving minimum bandwidth for UBR help? If so, how much?

# GR vs GFR

<b>GR</b>	<b>GFR</b>
per-class reservation	per-VC reservation
per-class scheduling	per-VC accounting/scheduling
No new signaling	Need new signaling
Can be done now	In TM4+

- Note: Typo in Contribution. Replace "Guaranteed Rate" in line 5 of Introduction by "Guaranteed Frame Rate" (twice).

# Guaranteed Rate Model

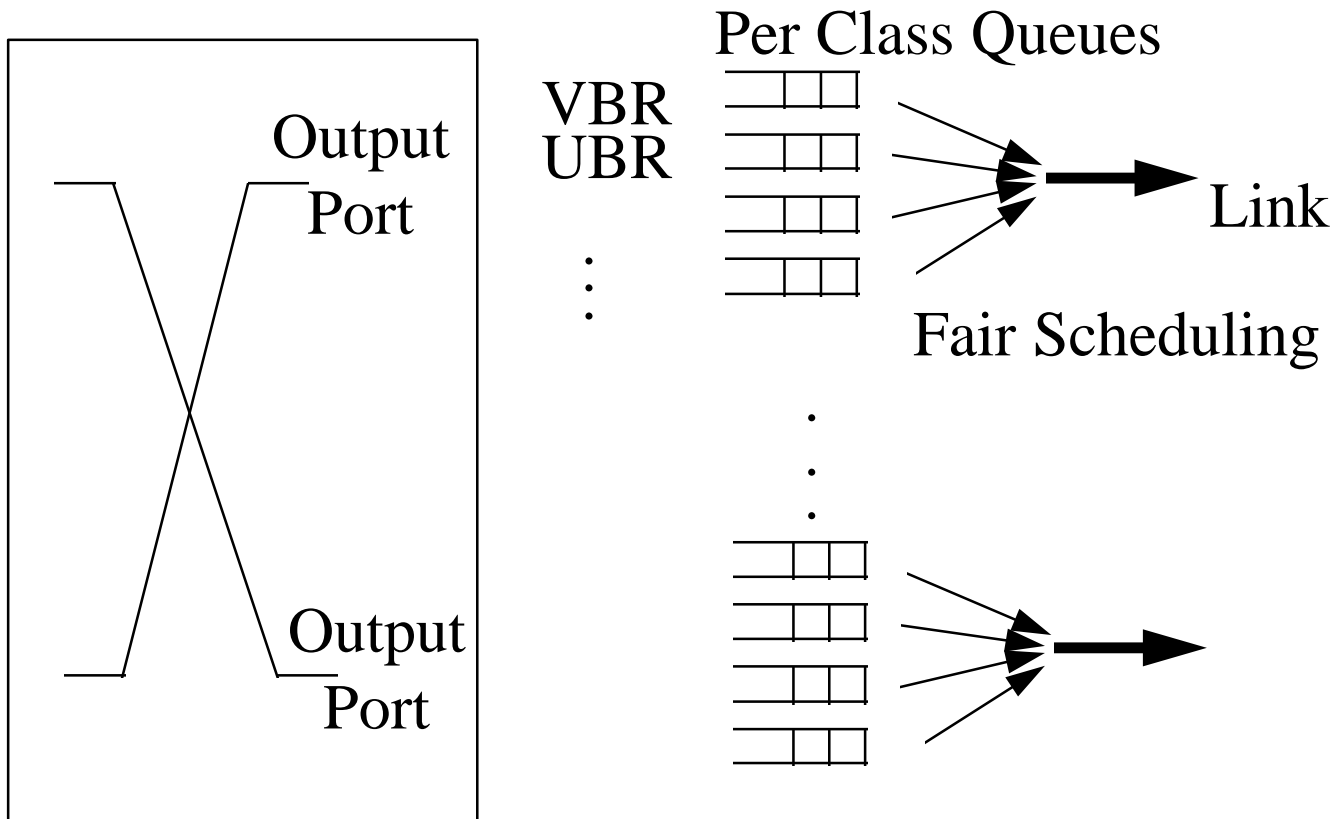

- ❑ W/o GR, VBR has strict priority over UBR
- ❑ With GR, UBR gets GR + left over

# Available UBR Capacity

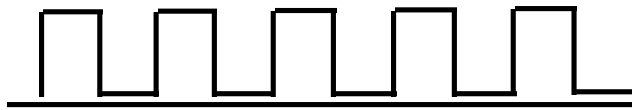

VBR on/off pattern



GR = 0.0  
Strict Priority

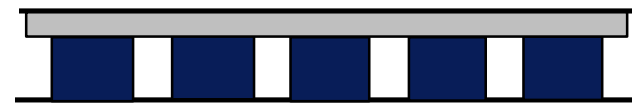

GR = 0.1



GR = 0.5



Guaranteed  
rate to VBR



Guaranteed  
rate to UBR



Available  
rate for UBR

# Efficiency Without GR

Configuration	# of Srcs	Buffer (cells)	VBR period (ms)	UBR	EPD	Selective Drop
LAN	5	1000	300	0.71	0.88	0.98
LAN	5	3000	300	0.83	0.91	0.92
LAN	5	1000	100	0.89	0.97	0.95
LAN	5	3000	100	0.96	0.95	0.96
LAN	5	1000	50	0.97	0.93	0.93
LAN	5	3000	50	0.95	0.97	0.97
WAN	5	12000	300	0.42	0.43	0.61
WAN	5	36000	300	0.55	0.52	0.96
WAN	5	12000	100	0.72	0.58	0.70
WAN	5	36000	100	0.95	0.97	0.97
WAN	5	12000	50	0.97	0.65	0.73
WAN	5	36000	50	0.97	0.98	0.98

- ❑ UBR can sustain short outages.
- ❑ Efficiency degrades significantly for long outages.

# Fairness without GR

Config-uration	# of Srcs	Buffer (cells)	VBR period (ms)	UBR	EPD	Selective Drop
LAN	5	1000	300	0.21	0.20	0.20
LAN	5	3000	300	0.95	0.99	0.99
LAN	5	1000	100	0.21	0.20	0.99
LAN	5	3000	100	0.91	0.93	0.96
LAN	5	1000	50	0.20	0.21	0.96
LAN	5	3000	50	0.93	0.99	1.00
WAN	5	12000	300	0.99	0.97	0.82
WAN	5	36000	300	0.88	0.97	0.63
WAN	5	12000	100	0.99	0.96	0.93
WAN	5	36000	100	1.00	0.88	0.89
WAN	5	12000	50	0.92	0.98	0.97
WAN	5	36000	50	1.00	0.97	0.80

□ In LAN cases, less fairness if UBR is starved.

# Efficiency

		EPD			Selective Drop			No EPD		
TCP\GR		0.50	0.10	0.00	0.50	0.10	0.00	0.50	0.10	0.00
Satellite	Reno	0.41	0.30	0.23	0.34	0.32	0.23	0.86	0.53	0.43
	Sack	0.92	0.94	0.91	0.93	0.89	0.87	0.90	0.92	0.88
	Vanilla TCP	0.75	0.78	0.73	0.81	0.76	0.79	0.85	0.78	0.83
WANs	Reno	0.96	0.84	0.64	0.81	0.71	0.45	0.96	0.83	0.50
	Sack	0.93	0.80	0.54	0.99	0.85	0.78	0.94	0.88	0.64
	Vanilla TCP	0.96	0.81	0.56	0.97	0.84	0.74	0.95	0.88	0.76
LANs	Reno	0.60	0.62	0.68	0.76	0.81	0.73	0.48	0.48	0.39
	Sack	0.88	0.79	0.91	0.94	0.90	0.94	0.63	0.75	0.64
	Vanilla TCP	0.63	0.67	0.71	0.81	0.82	0.82	0.65	0.48	0.40

# Fairness

		EPD			Selective Drop					
<b>TCP\GR</b>		<b>0.10</b>	<b>0.00</b>	<b>0.50</b>	<b>0.10</b>	<b>0.00</b>	<b>0.50</b>	<b>0.10</b>		
<b>Satellite</b>	Reno	0.74	0.99	0.85	0.96	0.99	0.86	0.85	0.94	
	Sack	0.98	0.88	1.00	0.96	0.91	0.94	0.88	0.94	
	Vanilla TCP	1.00	0.92	0.99	0.94	1.00	0.93			
<b>WANs</b>	0.95	0.78	0.96	0.77	0.72	0.95				
	0.96	0.89	0.89	0.80	0.85	0.88				
	Vanilla TCP	0.84	0.78	0.90	0.94	0.81	0.88	0.96	0.89	
<b>LANs</b>	Reno	0.88	0.83	0.63	0.98	0.82	0.82	0.67	0.81	
	Sack	0.89	0.82	0.49	0.93	0.71	0.69	0.53	0.51	
	TCP	0.83	0.59	0.94	0.89	0.65	0.76	0.64	0.59	

# Summary

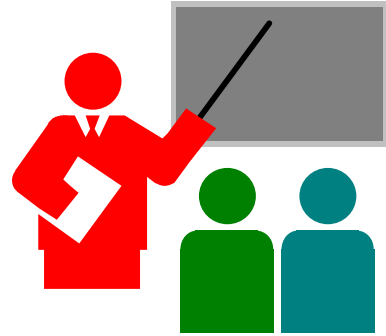

- ❑ Guaranteed rate is helpful in WANs.
- ❑ For WANs, the effect of  $GR=0.1$  is more than that obtained by EPD, SD, or FBA
- ❑ For LANs, guaranteed rate is not so helpful. Drop policies are more important.
- ❑ For Satellites, end-system policies seem more important.